

Crémones classiques renforcées en fonte



RY50/51/52/RA pour tringle 1/2 ronde 16x8, 16x5 mm

Composition

- 1 boîtier RY 50, 51, 52 ou RA
- 5 éléments de garniture

NB : Les éléments de garniture servent de coulants, chapiteaux et/ou gâches.



RY50 / 51 / 52
Pour tringle
1/2 ronde 16x8
P. 650



RA
Pour tringle
1/2 ronde 16x5
P. 650

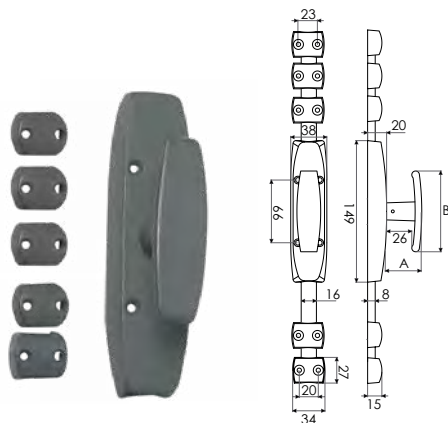

J04111.. RY51 standard

Code	Color	A	B	Icon	Dispo. (sem.)
J041118	APPRET	37	85		STOCKÉ

Code	Color	A	B	Icon	Dispo. (sem.)
J041110	EPOXY	37	85		Nous consulter

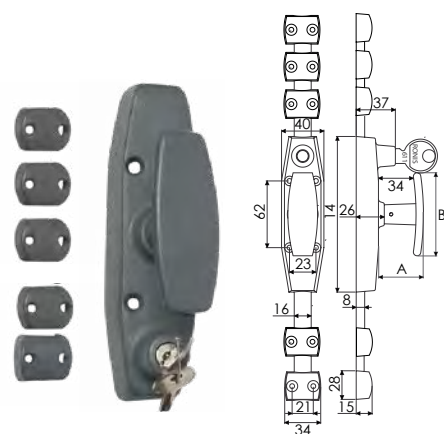

J041761 RY50 bouton à clé

Code	Color	A	B	Icon	Dispo. (sem.)
J041761	APPRET	37	79		STOCKÉ

Serrure s'ouvrant Ronis n°610 fournie avec 2 clés N°611.

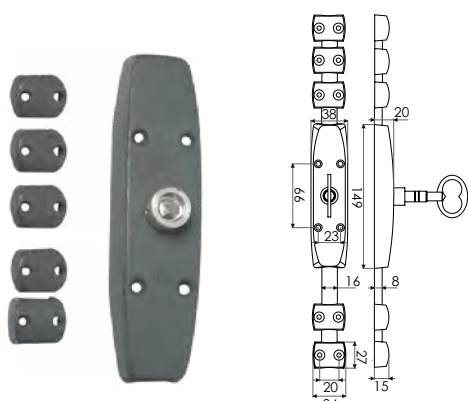

J041.. RY52 à fouillot avec carré intégré

Code	Color	A	B	Icon	Dispo. (sem.)
J041115	APPRET	11,5	18		STOCKÉ

Clé non fournie (voir P530). Carré 6 mm. Fouillot Ø12,5 mm.

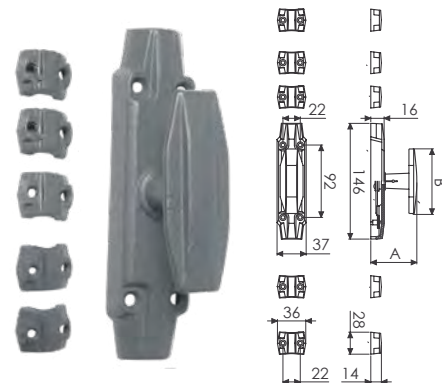

J.. RA standard

Code	Color	A	B	Icon	Dispo. (sem.)
J041320	APPRET	21	41		STOCKÉ

Code	Color	A	B	Icon	Dispo. (sem.)
J380002	BRUT	21	41		4