

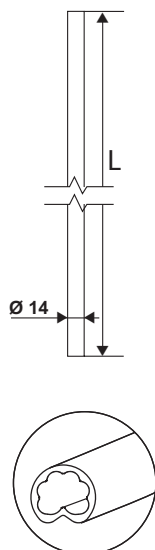

La tringle rainurée permet un positionnement aisé et un alignement parfait des composants.

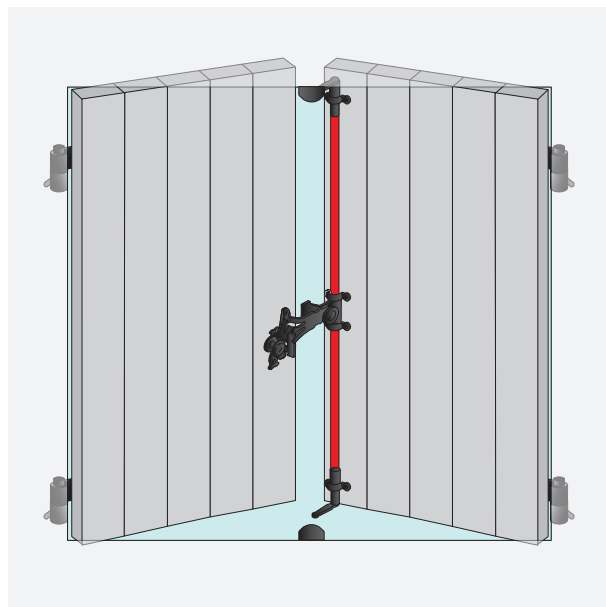

Tringle rainurée creuse

Code		L		Dispo. (sem.)
04P213J	9005 - 30%	1270	10	1
04P216J	9005 - 30%	1570	10	1
04P223J	9005 - 30%	2270	10	1
04P227J	9005 - 30%	2700	10	1
04T246J	9005 - 30%	4600	10	1
04P221E	9005 - 65%	2070	10	4
04P213P	9016 - 80%	1270	10	2
04P216P	9016 - 80%	1570	10	2
04P223P	9016 - 80%	2270	10	2
04P227P	9016 - 80%	2700	10	2
04P246P	9016 - 80%	4600	10	1

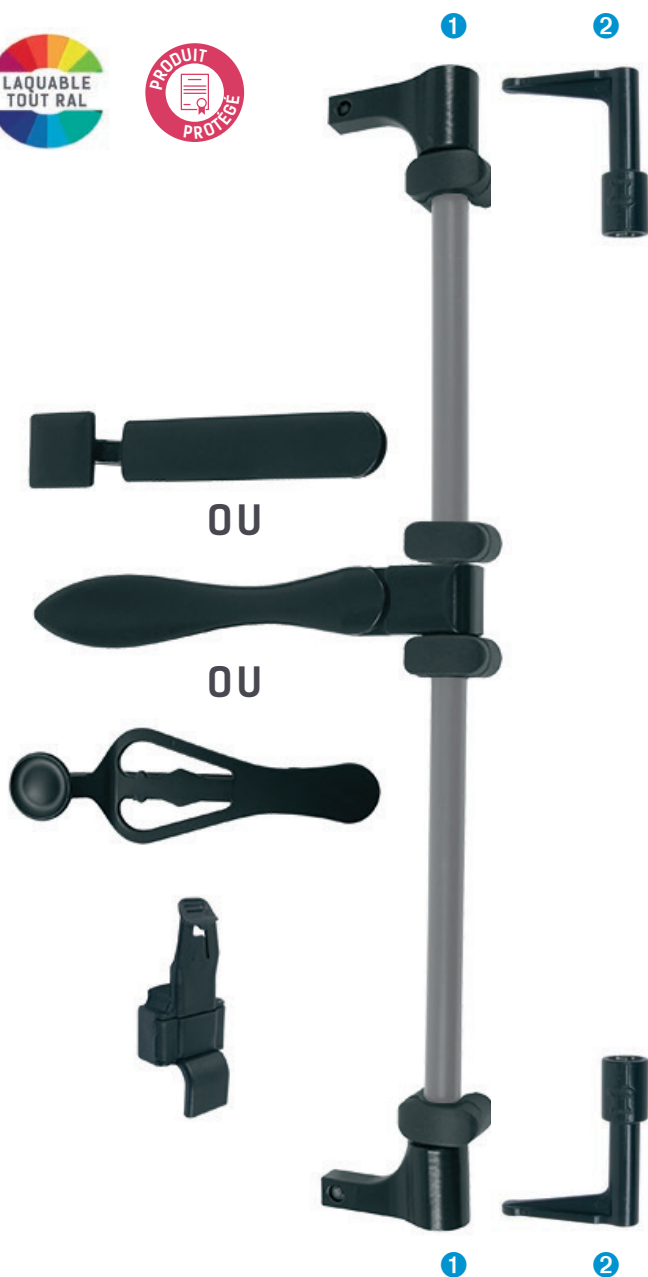
Espagnolettes
CONNECT**Sachet d'accessoires poignée Droite Connect**

Code Dispo. (sem.)

1 Avec embout Connect

04PD50J	9005 - 30%	10	1
04PD50P	9016 - 80%	10	1

2 Avec embout zamak

04PD51P	9016 - 80%	10	2
---------	------------	----	---

Sachet d'accessoires poignée Hélice Connect

Code Dispo. (sem.)

1 Avec embout Connect

04PE50J	9005 - 30%	10	1
04PE50P	9016 - 80%	10	1

Sachet d'accessoires poignée Feuille Connect

Code Dispo. (sem.)

1 Avec embout Connect

04PF50J	9005 - 30%	10	1
04PF50P	9016 - 80%	10	1

2 Avec embout zamak

04PF51J	9005 - 30%	10	2
04PF51P	9016 - 80%	10	2

Composition du sachet* :

- 1 poignée
- 1 panneton
- 1 support composite avec sécurité (Non laquable)
- 1 embout haut
- 1 embout bas
- 4 lacets S8 composite (Non laquable)

* Conditionnement en sachet avec les éléments ci-dessus.

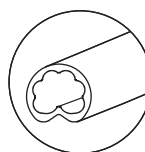

Compatibles avec tringles aluminium rainurées creuses P. 3-2

Espagnolettes
CONNECT

OU



OU

**Ensemble d'accessoires poignée Droite Connect**

Code

Dispo.
(sem.)**1 Avec embout Connect**

04PD10J	9005 - 30%	10	1
---------	------------	----	---

Ensemble d'accessoires poignée Hélice Connect

Code

Dispo.
(sem.)**1 Avec embout Connect**

04PE10J	9005 - 30%	10	1
04PE10P	9016 - 80%	10	1

Ensemble d'accessoires poignée Feuille Connect

Code

Dispo.
(sem.)**1 Avec embout Connect**

04PF10J	9005 - 30%	10	1
04PF10P	9016 - 80%	10	1

Composition de l'ensemble* :

- 1 poignée
- 1 panneton
- 1 support composite avec sécurité (Non laquable)
- 1 embout haut
- 1 embout bas

* Conditionnement en sachet avec les éléments ci-dessus.

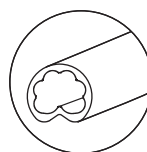
Compatibles avec tringles aluminium rainurées creuses
P. 3-2

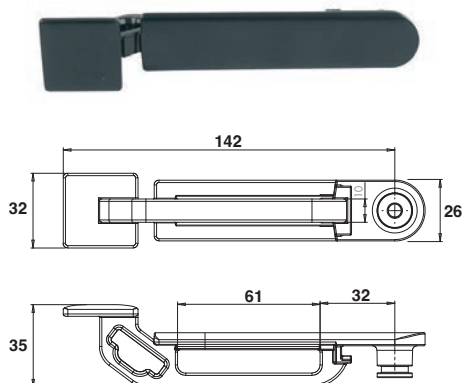

Poignée Droite

Code			Dispo. (sem.)
04PD21J	9005 - 30%	50	1
04PD21P	9016 - 80%	50	1

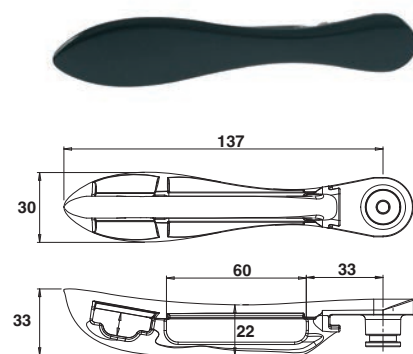

Poignée Hélice

Code			Dispo. (sem.)
04PD22J	9005 - 30%	50	1
04PD22P	9016 - 80%	50	1

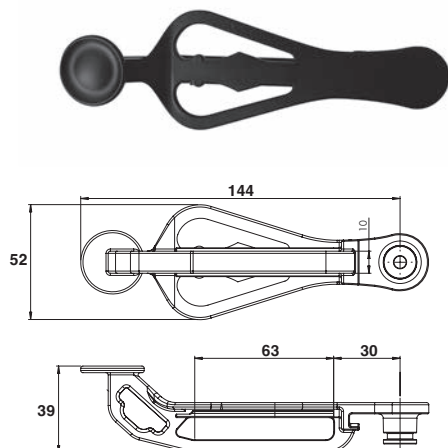

Poignée Feuille

Code			Dispo. (sem.)
04PD23J	9005 - 30%	50	1
04PD23P	9016 - 80%	50	1



1

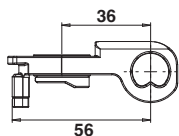

2

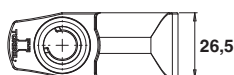

1

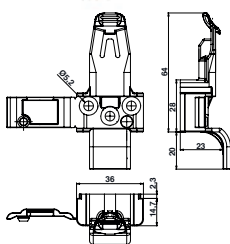
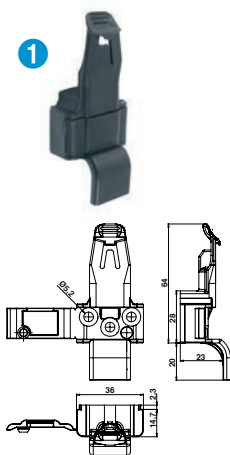

2

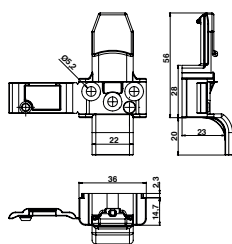
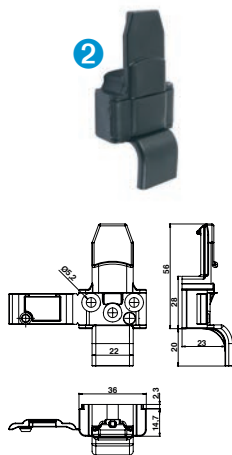

1

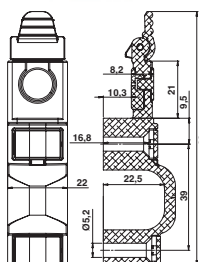
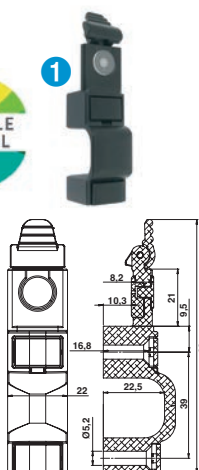

2

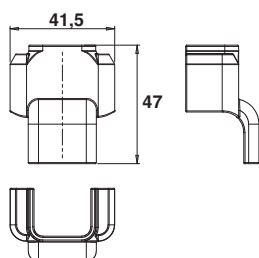
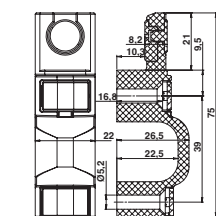
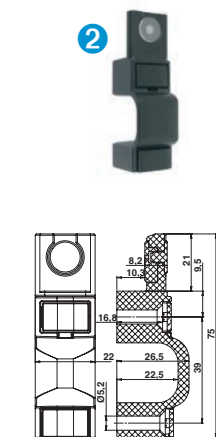

**Panneton d'espagnolette CONNECT
+ vis + circlips + tampons**

Code	Dispo. (sem.)
------	---------------

1 Sans canon			
04PD30J	9005 - 30%	50	1
04PD30P	9016 - 80%	50	1
2 Avec canon			
04PD33J	9005 - 30%	50	1
04PD33P	9016 - 80%	50	2

**Support composite
avec cache-vis**

Code	Dispo. (sem.)
------	---------------

1 Avec sécurité			
04PD409		50	1
04PD40C		50	1
2 Sans sécurité			
04PD449		50	1
04PD44C		50	1

**Support aluminium
avec cache-vis**

Code	Dispo. (sem.)
------	---------------

1 Avec sécurité			
04PD46J		50	1
2 Sans sécurité			
04PD45J		50	2

**Capuchon aluminium
pour support d'espagnolette**

Code	Dispo. (sem.)
------	---------------

04PD41J	50	1
04PD41P	50	1

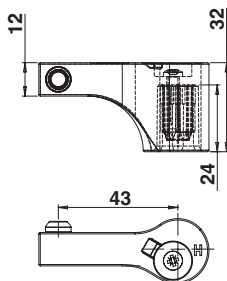

**Embout Connect
+ tampon + vis**

Code	Dispo. (sem.)
------	---------------

Modèle haut

04PD42J	9005 - 30%	50	1
---------	------------	----	---

Modèle bas

04PD43J	9005 - 30%	50	1
---------	------------	----	---

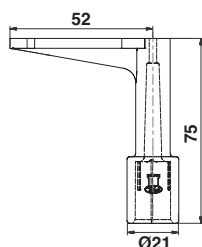

**Embout réglable zamak
emmençable**

Code	Dispo. (sem.)
------	---------------

Modèle haut

07TUZ5J	9005 - 30%	50	1
---------	------------	----	---

07TUZ5P	9016 - 80%	50	1
---------	------------	----	---

Modèle bas

07TUZ6J	9005 - 30%	50	1
---------	------------	----	---

07TUZ6P	9016 - 80%	50	1
---------	------------	----	---

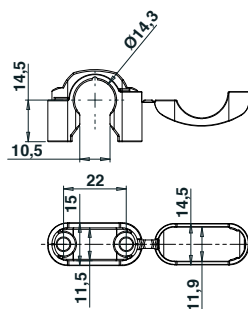

Lacet S8 composite

Code	Dispo. (sem.)	U
------	---------------	---

07405S89	150	1 %
----------	-----	-----

07405S8C	150	1 %
----------	-----	-----

Cache-vis intégré. Plus de stock de vis couleur. Esthétique renforcée.

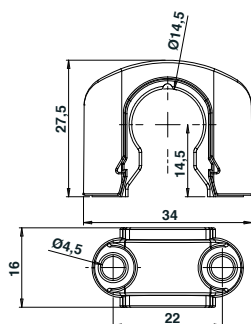

Lacet S9 thermolaquable zamak

Code	Dispo. (sem.)	U
------	---------------	---

0740400	BRUT	100	1 %
---------	------	-----	-----

074040J	9005 - 30%	100	1 %
---------	------------	-----	-----

Modèle brut avec base composite noir.



Esthétisme : novateur et moderne. Plus aucune vis apparente sur le volet.
Doigt de tirage : facilite la manipulation du volet.
Verrouillage de la poignée : empêche son soulèvement depuis l'extérieur.
Embouts de tringle réglables : permet d'ajuster au mieux les embouts par rapport aux dardennes.
Cales composite invisibles permettant de répondre aux différentes configurations de pose et de vantaux.
Entrebâillement des volets possible.

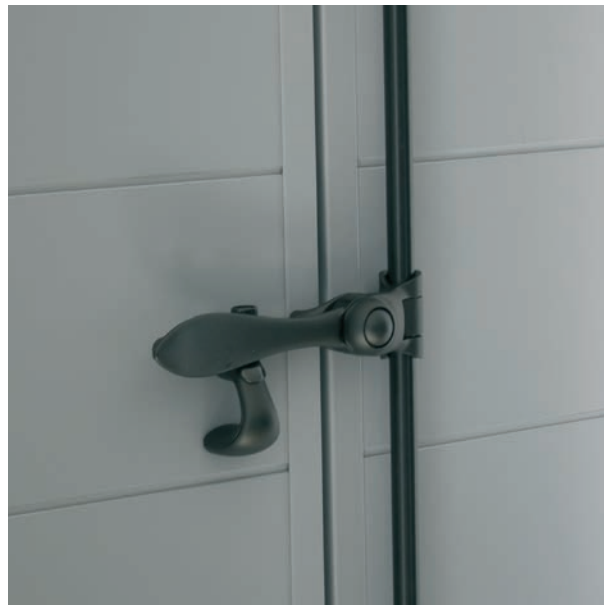

Composition

- 1 poignée montée sur panneton
- 1 support
- 1 capuchon de support
- 2 embouts réversibles + 2 lacets montés
- 1 lacet
- Jeu de tampons d'ajustement pour embouts et panneton

Sachet d'accessoires Hélice 2 embouts + lacets intégrés

Code	9005 - 30%	10	Dispo. (sem.)
04PA50J	9005 - 30%	10	1
04PA50P	9016 - 80%	10	2



Composition

- 1 poignée montée sur panneton
- 1 support
- 1 capuchon de support
- 2 embouts réversibles + 2 lacets montés
- 1 lacet
- Jeu de tampons d'ajustement pour embouts et panneton

Ensemble d'accessoires Hélice 2 embouts + lacets intégrés

Code	9005 - 30%	10	Dispo. (sem.)
04PA10J	9005 - 30%	10	1



Sécurité : grâce au verrouillage automatique de la poignée en position fermée ou entrebâillée, empêchant son soulèvement depuis l'extérieur.

3 positions de verrouillage : horizontale, verticale haute ou basse.

Montage aisé : grâce au panneton traversant équipé de vis pointeaux permettant la mise en oeuvre avec ou sans recoupe centrale du tube rainuré.

Confort d'utilisation : avec le tampon amortisseur situé sur le panneton qui préserve le volet au point de contact.

Composants esthétiques : avec leurs lignes fluides et novatrices.

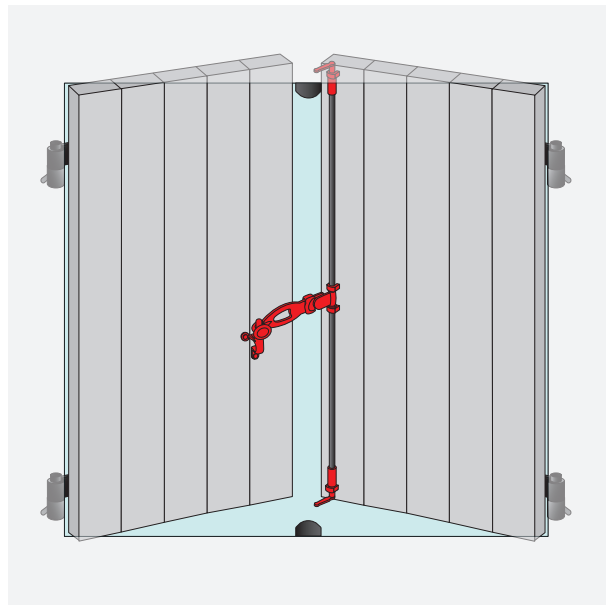

Ensemble d'accessoires ESPAS® support dans l'axe 3 pattes

Code			Dispo. (sem.)
04PS50J	9005 - 30%	10	1
04PS50P	9016 - 80%	10	2

Composition

- 1 poignée montée sur panneton
- 1 support dans l'axe
- 1 capuchon de support
- 1 embout haut
- 1 embout bas
- 4 lacets S4



Sachets accessoires ESPAS® support dans l'axe 3 pattes

Code			Dispo. (sem.)
04PS10J	9005 - 30%	10	1
04PS10P	9016 - 80%	10	2

Composition

- 1 poignée montée sur panneton
- 1 support dans l'axe
- 1 capuchon de support
- 1 embout haut
- 1 embout bas

Les lacets sont à commander séparément pour l'ensemble d'accessoires.



Fiabilité : l'alignement de tous les composants est assuré grâce à la rainure. Le positionnement des lacets garantit une tenue parfaite après assemblage.
Réversibilité : utilisation à droite comme à gauche.
Sécurité : grâce au support de sécurité fourni.

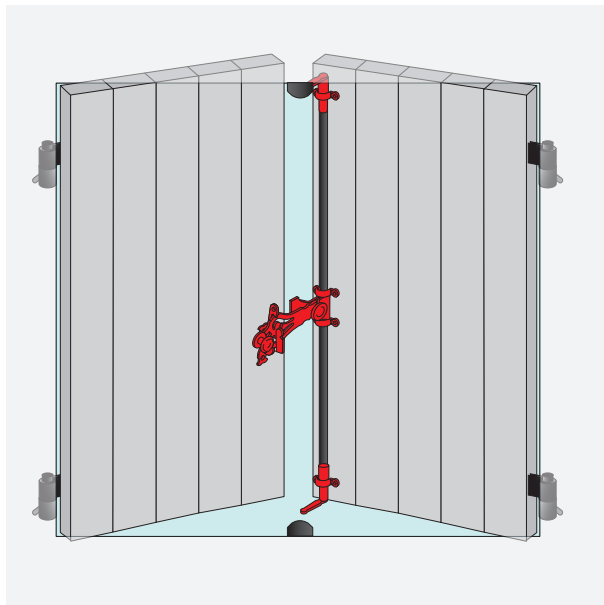

Composition

- 1 poignée montée sur panneton
- 1 support de sécurité
- 1 capuchon de support
- 1 embout haut
- 1 embout bas
- 4 lacets S1

Sachet d'accessoires TUBRAIN® poignée feuille aluminium (panneton moulé)

Code	Dispo. (sem.)
04P1S5J 9005 - 30%	25 1
04P1S5P 9016 - 80%	25 2



Composition

- 1 poignée montée sur panneton
- 1 support de sécurité
- 1 capuchon de support
- 1 embout haut
- 1 embout bas

Ensemble d'accessoires TUBRAIN® poignée feuille aluminium (panneton moulé)

Code	Dispo. (sem.)
04P1S1J 9005 - 30%	25 1
04P1S1P 9016 - 80%	25 2

Les lacets sont à commander séparément pour l'ensemble d'accessoires.



Sécurité : grâce au verrouillage automatique de la poignée en position fermée ou entrebâillée, empêchant son soulèvement depuis l'extérieur.
3 positions de verrouillage : horizontale, verticale, haute ou basse.
Montage aisé : la poignée sur panneton traversant peut être laissée libre sur la tringle et fixée à hauteur souhaitée sur chantier.
Fiabilité : l'alignement de tous les composants est assuré grâce à la rainure. Le positionnement des lacets garantit une tenue parfaite après assemblage.
Polyvalence : les embouts courbes permettent une adaptation aux linteaux droits comme cintrés.
Composants esthétiques : avec leurs lignes fluides et novatrices.

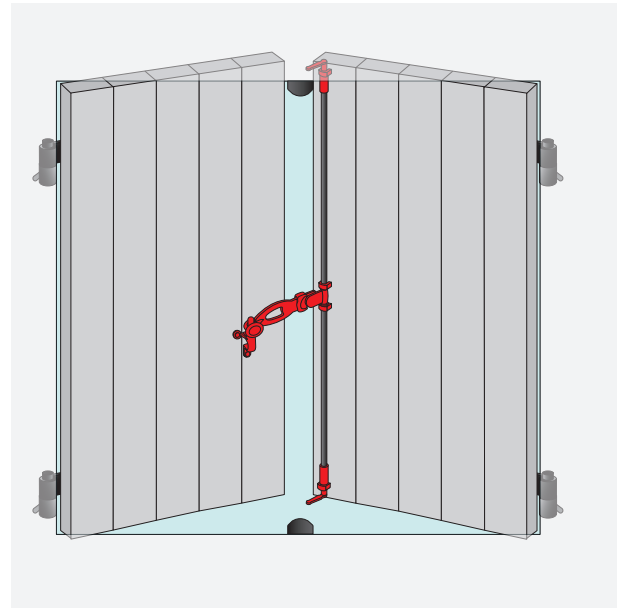

Composition

- 1 poignée montée sur panneton
- 1 support dans l'axe
- 1 embout haut
- 1 embout bas

Ensemble d'accessoires ESPAS® composite support dans l'axe 3 pattes

Code			Dispo. (sem.)
3004116		50	1
300411C		50	1



Composition

- 1 poignée montée sur panneton
- 1 support déporté
- 1 embout haut
- 1 embout bas

Ensemble d'accessoires ESPAS® composite support déporté 2 pattes

Code			Dispo. (sem.)
3002116		50	1
300211C		50	1

Le support déporté est préconisé dans le cas de volets pourvus d'un couvre-joint ou de volets persiennés.

Les lacets sont à commander séparément pour l'ensemble d'accessoires.



3 positions de verrouillage : horizontale, verticale, haute ou basse.
Montage aisé : grâce au panneton traversant équipé de vis pointeaux permettant la mise en oeuvre avec ou sans recoupe centrale du tube rainuré.
Confort d'utilisation : avec le tampon amortisseur situé sur le panneton qui préserve le volet au point de contact.
Composants esthétiques : avec leurs lignes fluides et novatrices.

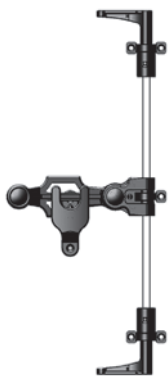
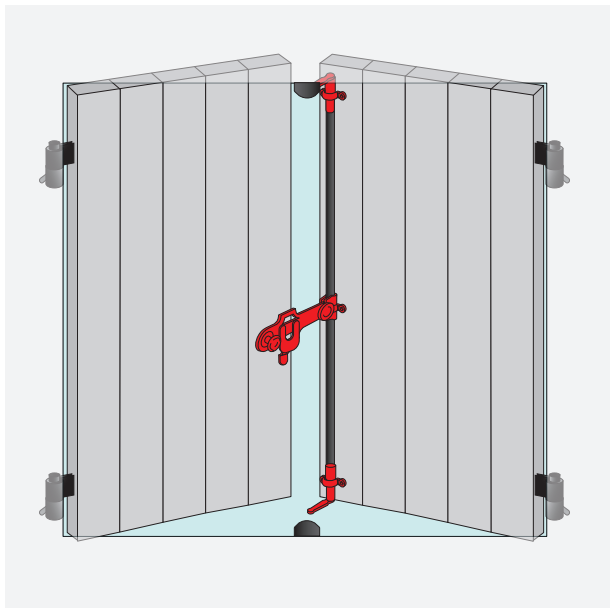

Composition

- 1 poignée montée sur panneton
- 1 support
- 1 embout haut
- 1 embout bas
- 3 lacets S1 composite

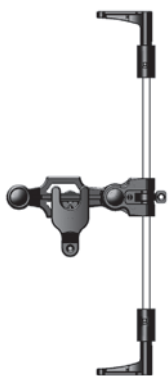

Composition

- 1 poignée montée sur panneton
- 1 support
- 1 embout haut
- 1 embout bas

Sachet d'accessoires CLIC composite poignée contemporaine

Code	Color	Dispo. (sem.)
3303116	Black	50

Ensemble d'accessoires CLIC composite poignée contemporaine

Code	Color	Dispo. (sem.)
3304116	Black	50
330411C	White	50

Les lacets sont à commander séparément pour l'ensemble d'accessoires.



Montage aisé : la poignée sur panneton traversant peut être laissée libre sur la tringle et fixée à hauteur souhaitée sur chantier.

Fiabilité : l'alignement de tous les composants est assuré grâce à la rainure. Le positionnement des lacets garantit une tenue parfaite après assemblage.

Support à bossage : pour un meilleur maintien de la poignée sur le support.

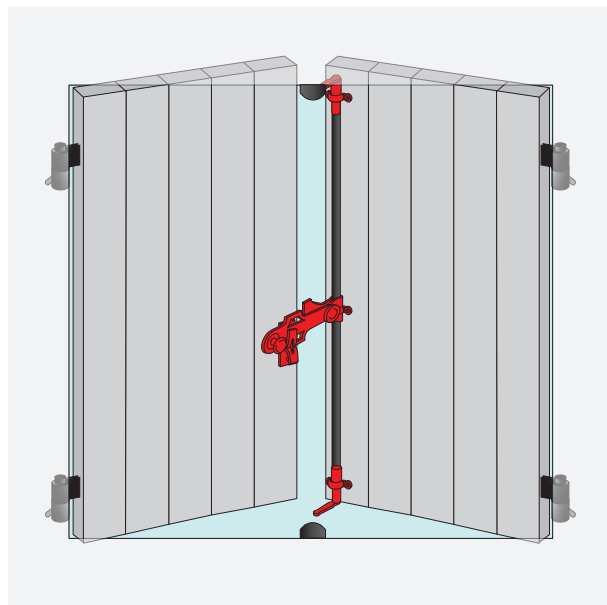

Composition

- 1 poignée montée sur panneton
- 1 support composite
- 1 embout haut
- 1 embout bas
- 3 lacets S1 composite

Sachet d'accessoires TUBRAIN® composite

Code			Dispo. (sem.)
04P2S59		50	1
04P3S59		50	1



Composition

- 1 poignée montée sur panneton
- 1 support composite
- 1 embout haut
- 1 embout bas

Ensemble d'accessoires TUBRAIN® composite

Code			Dispo. (sem.)
04P2S19		50	1
04P3S19		50	1

Les lacets sont à commander séparément pour l'ensemble d'accessoires.



Discrète : utilisation préconisée dans le cas de tableaux étroits.
Réversible : utilisation à droite comme à gauche grâce aux lacets réversibles.

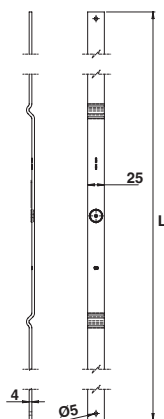
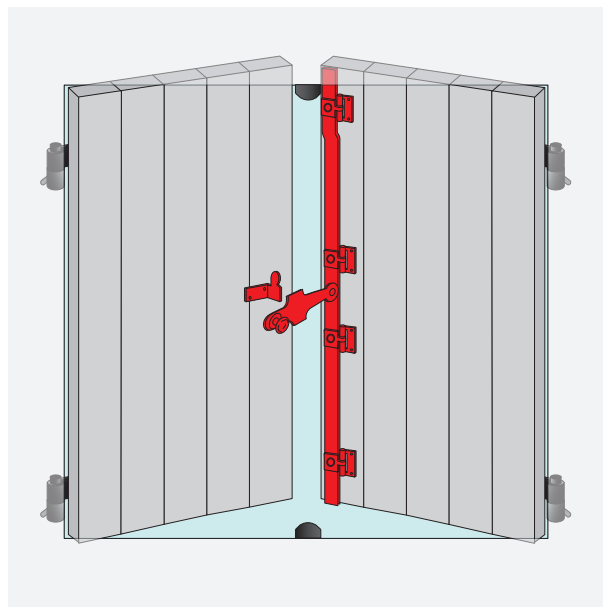

Tige d'espagnolette plate aluminium

Code		L		Dispo. (sem.)
06AL17J	9005 - 30%	1670	10	2
06AL25J	9005 - 30%	2500	10	1
06AL25P	9016 - 80%	2500	10	2



Sachet d'accessoires espagnolette plate aluminium

Code			Dispo. (sem.)
06ALS1J	9005 - 30%	20	1
06ALS1P	9016 - 80%	20	2

Pour les butées hautes et basses, utiliser le modèle 502006.

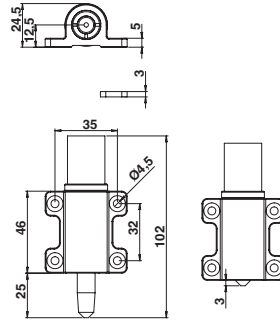

Verrou SDO pêne long 46 mm alu + accessoires laquables

Code	Dispo. (sem.)
Modèle haut	
95PA039	10
95PA049	10
Modèle bas	
95PA019	10
95PA029	10

Verrou SDO pêne long 66 mm inox + accessoires laquables

Code	Dispo. (sem.)
Modèle haut	
95PA659	10
Modèle bas	
95PA649	10

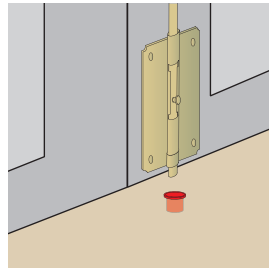
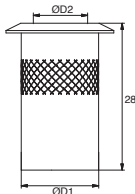

Gâche à ressort antipoussière

Code	ØD1	ØD2	Dispo. (sem.)
95PAA39	16	12	1
95PAA49	18	14	1

Embouts



Modèle haut

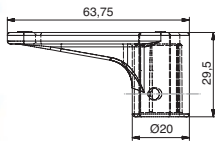

Modèle bas

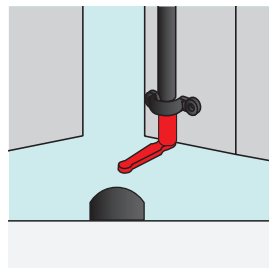

Embout zamak à vis pointeau

Code	Dispo. (sem.)
Modèle haut	
07PN07J	100
07PN07P	100
Modèle bas	
07PN08J	100
07PN08P	100

Réglables en hauteur, grâce à la vis pointeau, ils permettent un ajustement aux butées après la pose.



Modèle haut

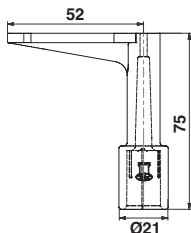

Modèle bas

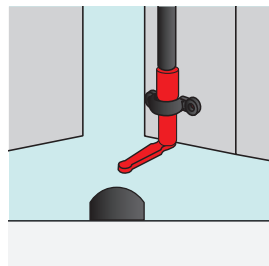

Embout réglable zamak emmenchable

Code	Dispo. (sem.)
Modèle haut	
07TUZ5J	50
07TUZ5P	50
Modèle bas	
07TUZ6J	50
07TUZ6P	50

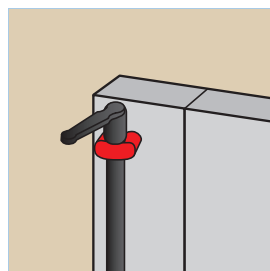
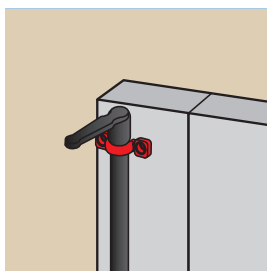
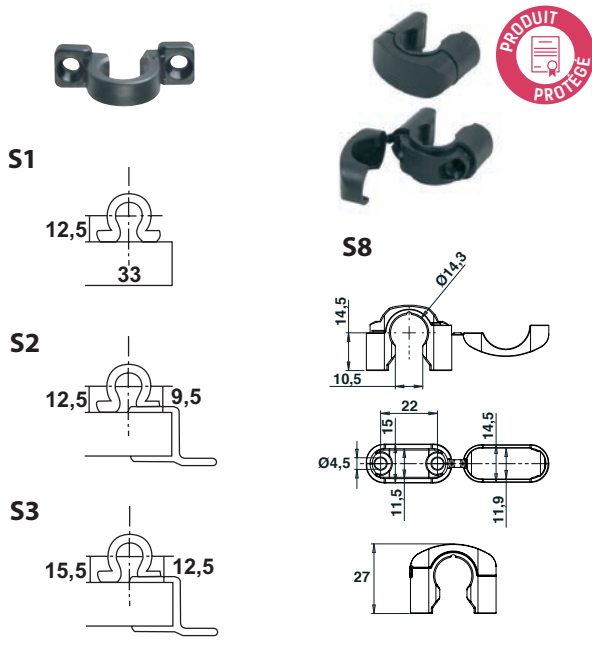

Lacet

Code	Type	Dispo. (sem.)	U
Composite S1			
0740249	S1	150	1 %
0740269	S1	150	1 %
Composite S2			
0740259	S2	150	1 %
0740279	S2	150	1 %
Composite S3			
0740339	S3	150	1 %
0740349	S3	150	1 %
Composite S8			
07405S89	S8	150	1 %
07405S89	S8	150	1 %
Zamak S1			
0740700	BRUT	S1	100 1 %
074070J	9005 - 30%	S1	100 1 %
074070P	9016 - 80%	S1	100 4 %

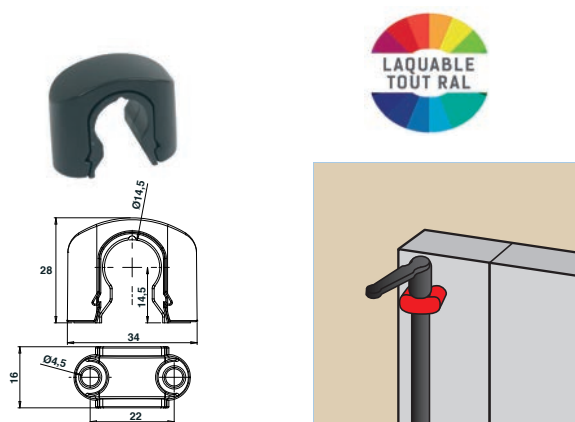

Lacet S9 thermolaquable zamak

Code	Type	Dispo. (sem.)	U
0740400	BRUT	100	1 %
074040J	9005 - 30%	100	1 %

* Modèle brut livré avec base composite noir.

Produit en zamak thermolaquable. Personnalisation à couleur possible à l'infini. Cache zamak rendant les vis invisibles, clipsé sur une embase composite. Compatible avec vis tôle Ø4,2 mm et rivet éclaté Ø4 x 30 mm (code 880404300F).

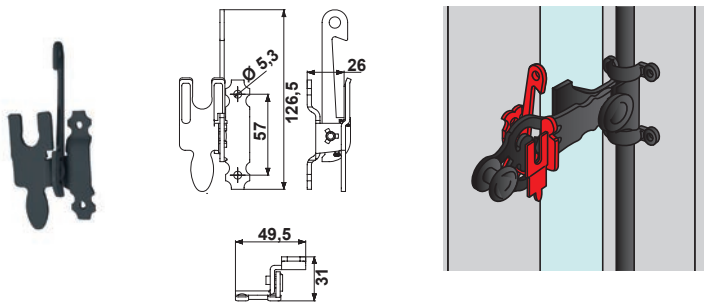

Support entrebâilleur de sécurité aluminium

Code			Dispo. (sem.)
------	--	--	---------------

Modèle de droite

07AL41J	9005 - 30%	50	1
07AL41P	9016 - 80%	50	2

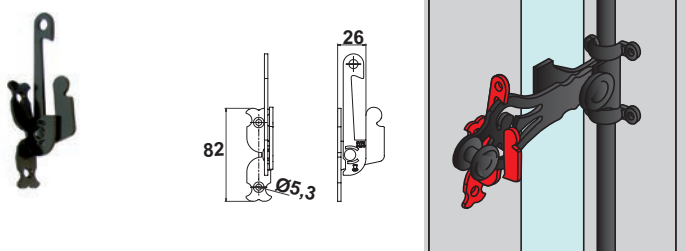

Support de sécurité aluminium

Code			Dispo. (sem.)
------	--	--	---------------

07AL10J	9005 - 30%	50	1
07AL10P	9016 - 80%	50	2

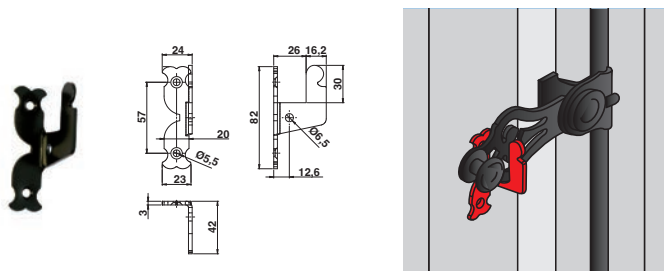

Support rustique aluminium

Code			Dispo. (sem.)
------	--	--	---------------

07AL01J	9005 - 30%	50	1
07AL01P	9016 - 80%	50	2

Modèle droite

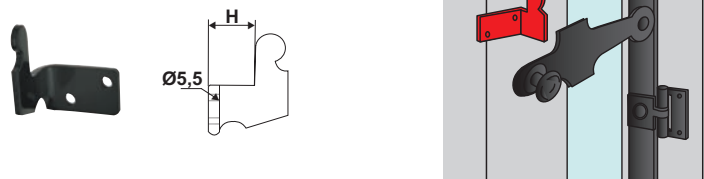

Support à plaquer aluminium

Code		H		Dispo. (sem.)
------	--	---	--	---------------

Modèle droite

07AL32J	9005 - 30%	18	50	4
07AL30J	9005 - 30%	25	50	2

Modèle gauche

07AL31J	9005 - 30%	25	50	2
---------	------------	----	----	---

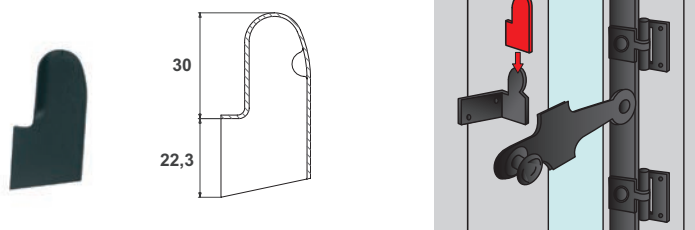

Capuchon protecteur composite pour support aluminium

Code			Dispo. (sem.)
------	--	--	---------------

07AL159		50	1
07AL169		50	1
07AL179	INCOLORE	50	1

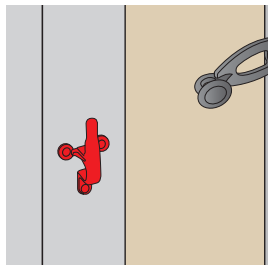
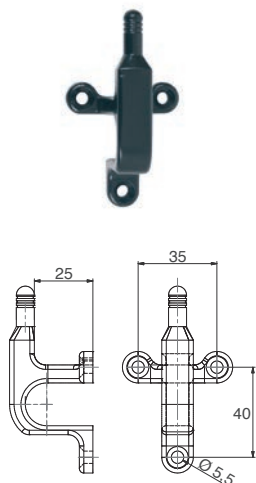

Support 3 pattes zamak

Code		Dispo. (sem.)
07AL73J	9005 - 30%	50 1
07AL73P	9016 - 80%	50 2

Modèle droite

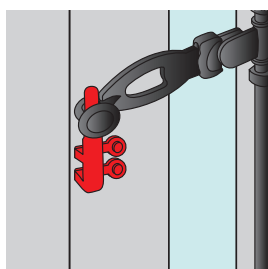
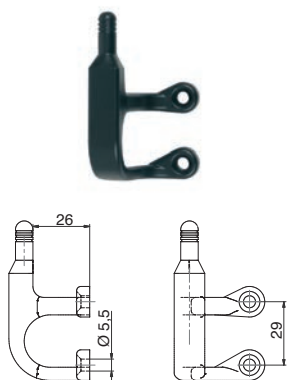

Support 2 pattes déporté zamak

Code		Dispo. (sem.)
07AL70J	9005 - 30%	25 1
07AL70P	9016 - 80%	25 2

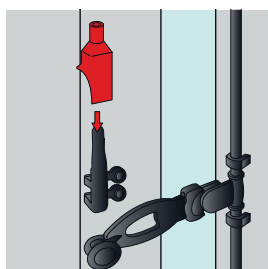
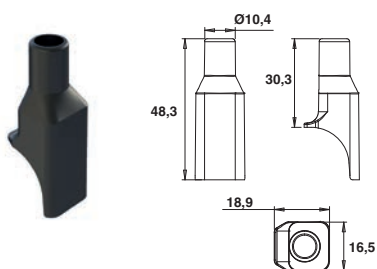

Capuchon composite supports 2 et 3 pattes zamak

Code		Dispo. (sem.)
07AL716		50 1
07AL71C		50 1
07AL719	INCOLORE	50 1

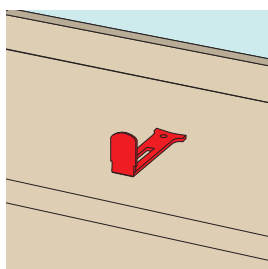
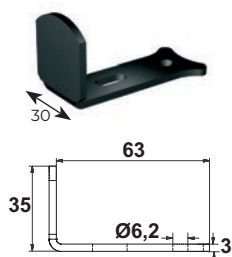

Dardenne aluminium DMK

Code			Dispo. (sem.)
07PBK3J	9005 - 30%	200	1
07PBK3P	9016 - 80%	200	2

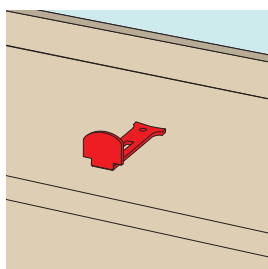
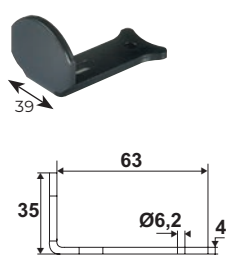

Dardenne aluminium type L

Code			Dispo. (sem.)
07PAK2J	9005 - 30%	100	1
07PAK2P	9016 - 80%	100	2
07PAK2Q	9016 - 30%	100	2
07PAK2S	9010 - 30%	100	2

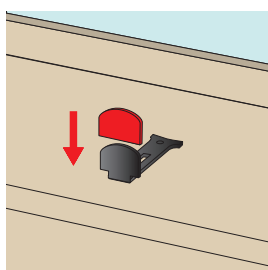
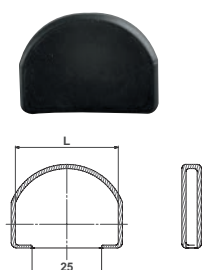

Capuchon composite pour dardenne aluminium

Code		L		Dispo. (sem.)
07AL129		34	50	1
07AL399		39	50	1
07AL139		34	50	1
07AL409		39	50	1

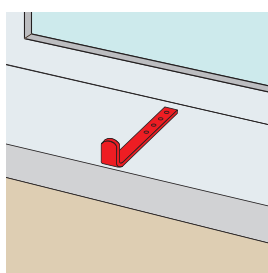
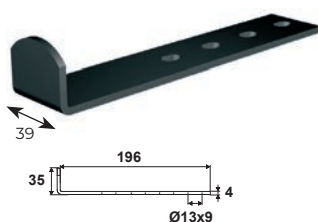

Dardenne aluminium longue

Code			Dispo. (sem.)
07PAK7J	9005 - 30%	50	2
07PAK7P	9016 - 80%	50	2

Longueur 200 pour isolation extérieure.

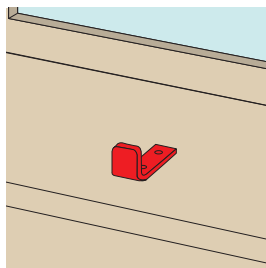
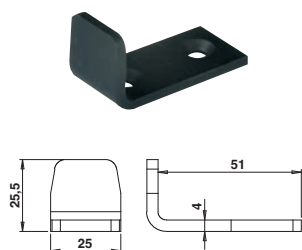

Dardenne équerre aluminium

Code	Dispo. (sem.)
502006J	20 4
502006P	20 4

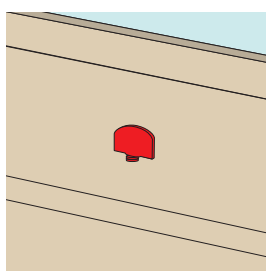
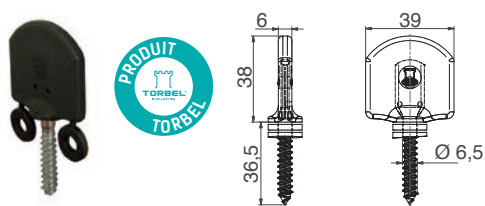

Dardenne S4000 surmoulée à visser

Code	Dispo. (sem.)
07PCK1J	100 1
07PCK1Q	100 2

La version à visser est proposée avec 2 rondelles détachables permettant d'ajuster si besoin la position de la dardenne en hauteur.

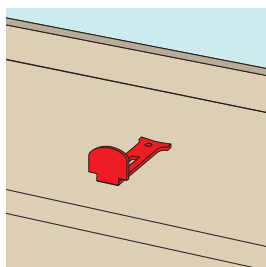
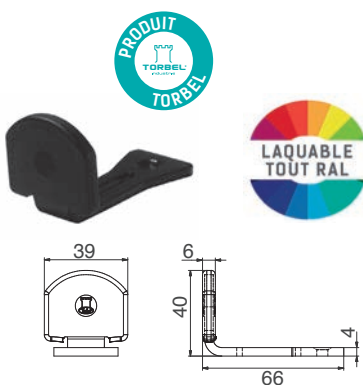

Dardenne S4000 surmoulée type L

Code	Dispo. (sem.)
07PCK5J	100 1

Trou oblong qui permet le réglage de la position de la dardenne dans la longueur, la mise en œuvre de ce produit est facilitée.

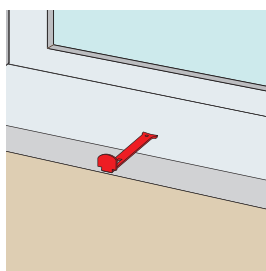
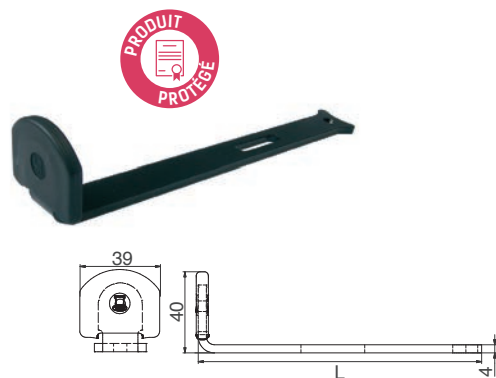

Dardenne S4000 pour isolation extérieure

Code	L	Dispo. (sem.)
07PCK6J	140	100 1
07PCK7J	200	100 1

Adaptées pour des configurations de pose avec isolation thermique par l'extérieur.

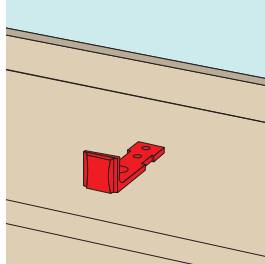
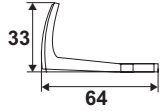

Dardenne composite

Code			Dispo. (sem.)
07P3019		100	1
07P2019		100	2

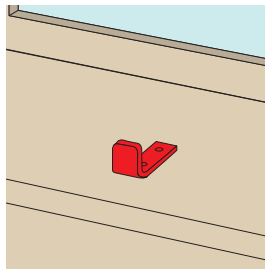
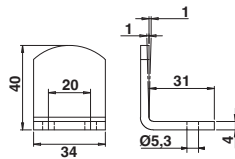

Dardenne aluminium pour précadre

Code			Dispo. (sem.)
07PAF4J		100	2

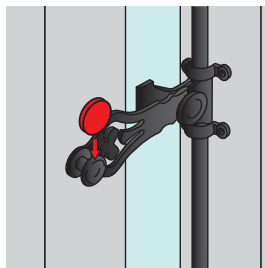
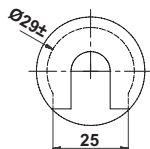

Capuchon composite pour poignée

Code			Dispo. (sem.)
07AL459		50	1

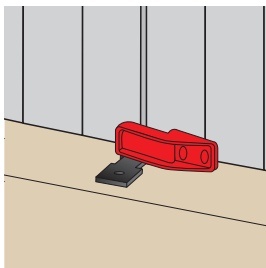
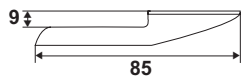

Crochet de rappel composite

Code			Dispo. (sem.)
07Q2019		50	1

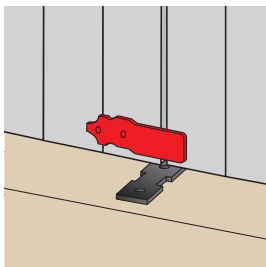
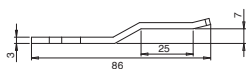

Crochet de rappel aluminium pour dardenne surmoulée

Code			Dispo. (sem.)
503011J		50	1
503011P		50	2

Economise la pose d'une espagnolette.

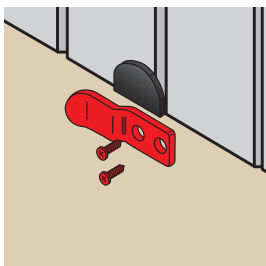
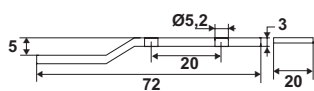

Crochet de rappel aluminium

Code			Dispo. (sem.)
503007J		20	1
503007P		20	2

Economise la pose d'une espagnolette.