

Tourniquets marseillais

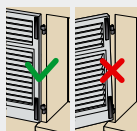

La mise en œuvre des fermetures est encadrée par le DTU 34-4, s'y référer pour éviter tout danger.



Bien s'assurer que le vantail soit monté plaqué et serré sur la façade.



En cas de vent, fermer les volets.



Pour les volets de grandes tailles, utiliser uniquement les arrêts adaptés



Conseils de pose P.113



Plus d'infos sur www.torbel.fr

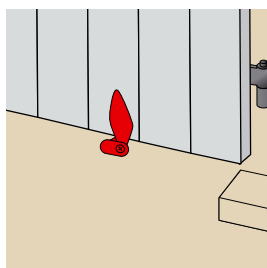
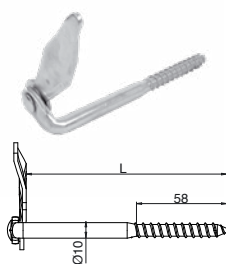

94..

Tourniquet marseillais à vis *
tête forgée

Code		L		Dispo. (sem.)
9409062	Z.BLANC	110	25	STOCKÉ
9409072	Z.BLANC	130	25	STOCKÉ

Code		L		Dispo. (sem.)
9410192	Z.BLANC	180	25	4

La tête forgée confère au produit une grande solidité.

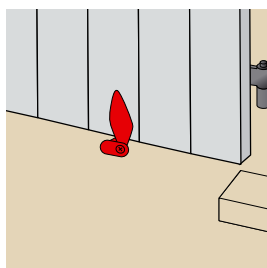
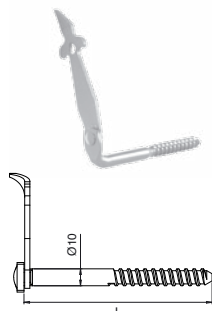

P360021...

Tourniquet marseillais à vis *
tête forgée feuille de lys

Code		L		Dispo. (sem.)
P36002111C	Z.BLANC	115	25	4
P36002113C	Z.BLANC	135	25	4

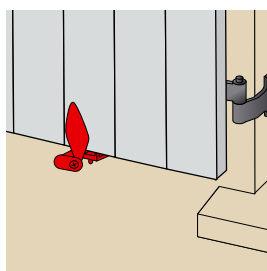
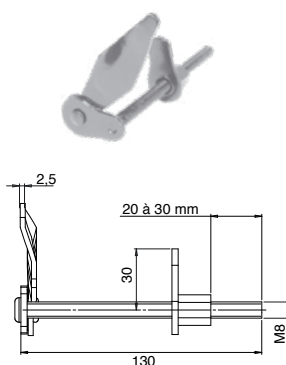

9429142

Tourniquet marseillais métrique *
butée hexagonale tête soudée

Code			Dispo. (sem.)
9429142	Z.BLANC	100	Nous consulter

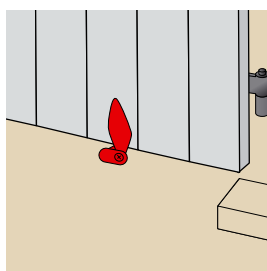

J520..

Tourniquet marseillais à vis estampé *

Code		L		Dispo. (sem.)
J520302	Z.BLANC	110	20	STOCKÉ
J520303	Z.BLANC	130	20	STOCKÉ

Code		L		Dispo. (sem.)
J520301	Z.BLANC	90	20	Nous consulter
J520514	Z.BLANC	180	20	4

Meuler chaque pièce zinguée avant toute soudure.

Tourniquets marseillais, arrêts

(*)



La mise en œuvre des fermetures est encadrée par le DTU 34-4, s'y référer pour éviter tout danger.

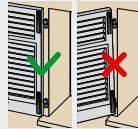

Bien s'assurer que le vantail soit monté plaqué et serré sur la façade.



En cas de vent, fermer les volets.



Pour les volets de grandes tailles, utiliser uniquement les arrêts adaptés



Conseils de pose P.113



Plus d'infos sur www.torbel.fr

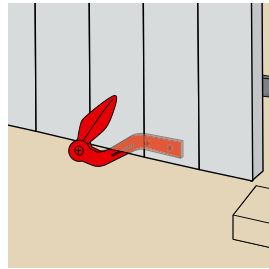
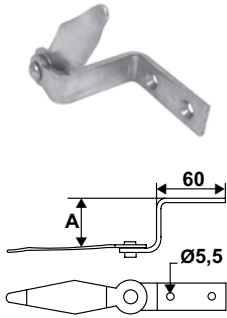

J52/941.. Tourniquet marseillais maisonnette * à visser

Code	Color	A	Dispo. (sem.)	
J520750	Z.BLANC	40	20	STOCKÉ
J520752	Z.BLANC	50	20	STOCKÉ

Code	Color	A	Dispo. (sem.)	
9416801	Z.BLANC	80	50	Nous consulter

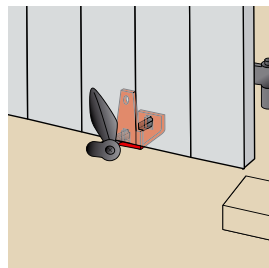
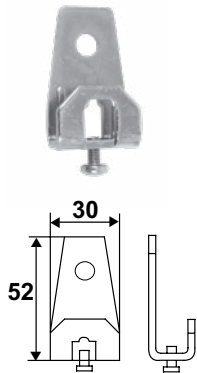

9408002 Butée de tourniquet marseillais type C

Code	Color	Dispo. (sem.)	
9408002	Z.BLANC	25	STOCKÉ

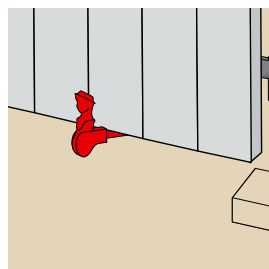
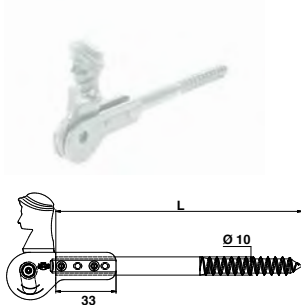

9426.. Arrêt tête bergère à vis *

Code	Color	L	Dispo. (sem.)	
9426082	Z.BLANC	115	50	4
9426102	Z.BLANC	135	50	4
9426122	Z.BLANC	155	50	4

Arrêts



La mise en œuvre des fermetures est encadrée par le DTU 34-4, s'y référer pour éviter tout danger.

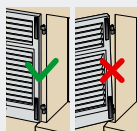

Bien s'assurer que le vantail soit monté plaqué et serré sur la façade.



En cas de vent, fermer les volets.



Pour les volets de grandes tailles, utiliser uniquement les arrêts adaptés



Conseils de pose P.113



Plus d'infos sur www.torbel.fr

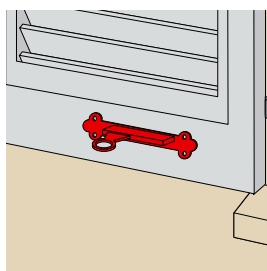
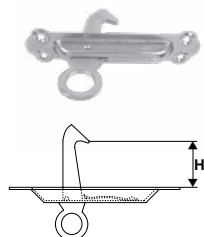

920 / J50.. Arrêt à paillette *

Code	Color	H	Weight	Dispo. (sem.)
9202012	Z.BLANC	40	50	STOCKÉ
9202082	Z.BLANC	45	50	STOCKÉ
J501518	Z.BLANC	55	50	STOCKÉ

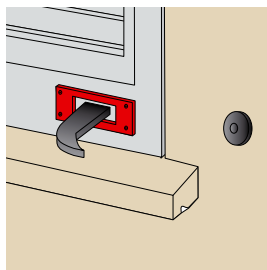
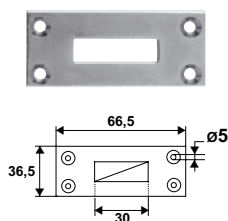

9202092 Contre-plaque d'arrêt à paillette

Code	Color	Weight	Dispo. (sem.)	U
9202092	Z.BLANC	50	STOCKÉ	%

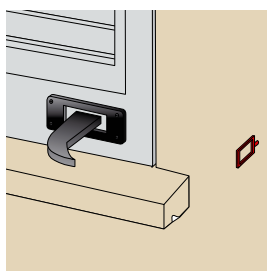
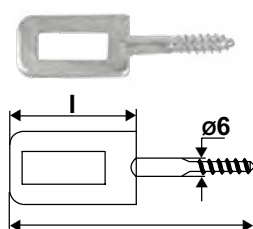

9202.. Gâche d'arrêt à vis *

Code	Color	L	I	H	Weight	Dispo. (sem.)
9202052	Z.BLANC	35	36	20	50	STOCKÉ
9202122	Z.BLANC	70	36	20	50	STOCKÉ

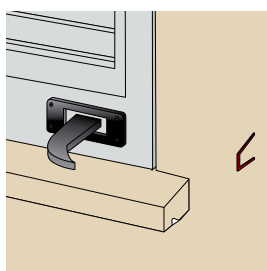

9202302 Gâche d'arrêt à fil *

Code	Color	Weight	Dispo. (sem.)	U
9202302	Z.BLANC	100	STOCKÉ	%

Meuler chaque pièce zinguée avant toute soudure.