

- Réalisée en rond plein Ø14.
- S'adapte à tous types de volets.
- Mise en œuvre assurée par 2 coupes pour la mise à dimension de la tige qui s'assemble par le panneton et par serrage de 2 boulons.
- Grande robustesse : séduira les poseurs à la recherche du meilleur rapport qualité/prix.

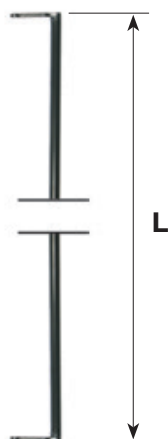

Tringle rond plein

Code		L		Dispo. (sem.)
Crochets droits soudés				
0420164		1600	5	1
0420204		2000	5	1
0420254		2500	1	1

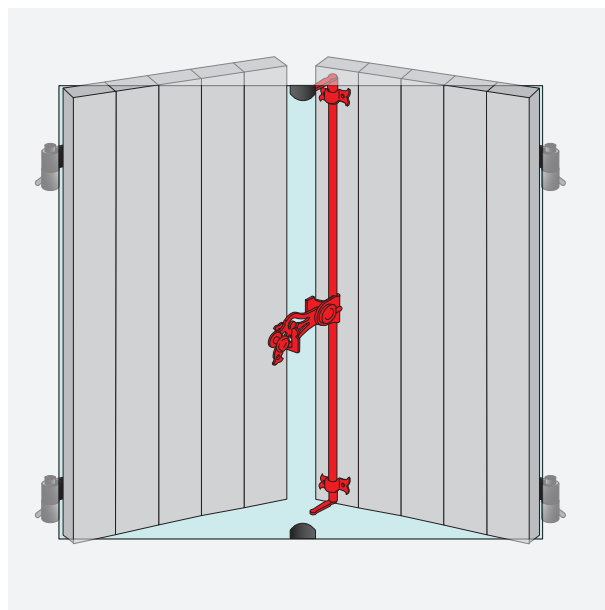
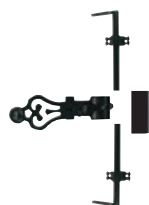

Pour composer 1 espagnolette complète, commander 1 tige et 1 sachet d'accessoires.

- 1) Recouper à hauteur de poignée.
- 2) Assembler à l'aide du panneton.
- 3) Enlever la partie superflue.



Sachet d'accessoires EVU

Code				Dispo. (sem.)
0420966		20		1

Composition

- 1 poignée montée sur panneton
- 2 boulons
- 2 lacets rustiques
- 1 lacet fil rond
- 1 support

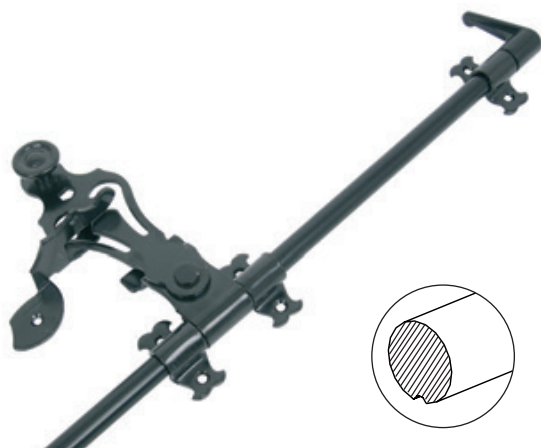

- Simplicité de stockage et de pose.
- Mise à longueur de la tringle en une seule coupe.
- Blocage de la poignée et des 2 embouts par vis 6 pans creux pointeau dans la rainure.
- Tringle rainurée pleine Provence compatible uniquement avec les accessoires Provence et inversement.

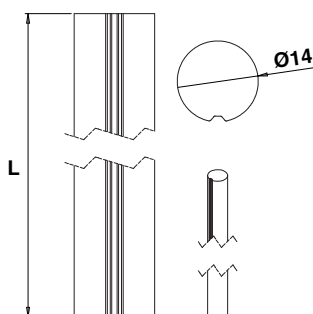
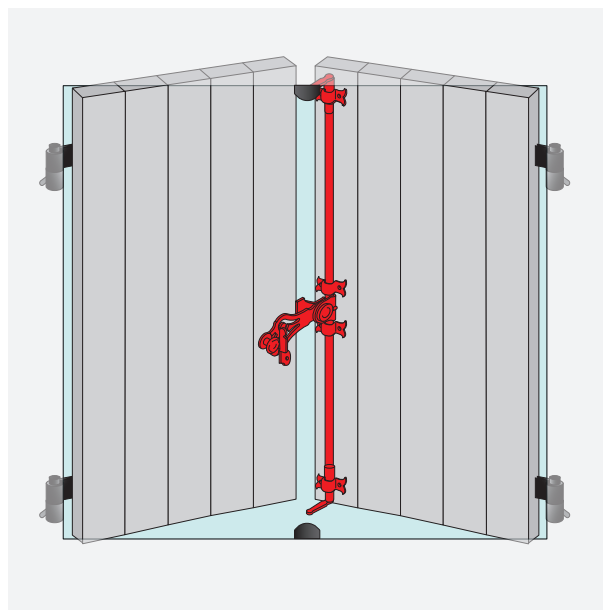

Tringle rainurée pleine Provence

Code	Color	L	Dispo. (sem.)
07PN154	Black	1600	5 1
07PN204	Black	2000	5 1
07PN254	Black	2500	1 1

Sachet d'accessoires Provence

Code	Color	Dispo. (sem.)
Crochets droits - Support sécurité - Lacets rustiques - Dardennes coudées		
07PNC3B14	Black	10 1
Crochets droits - Support sécurité - Lacets déportés - Dardennes coudées		
07PNC3B24	Black	10 1
Crochets courbes - Support sécurité - Lacets rustiques - Goujons coudé et droit		
07PNC3A14	Black	10 1

Composition

- 1 poignée, 1 panneton
- 1 sachet visserie
- 1 embout haut
- 1 embout bas
- 4 lacets
- 1 support
- 2 dardennes ou goujons

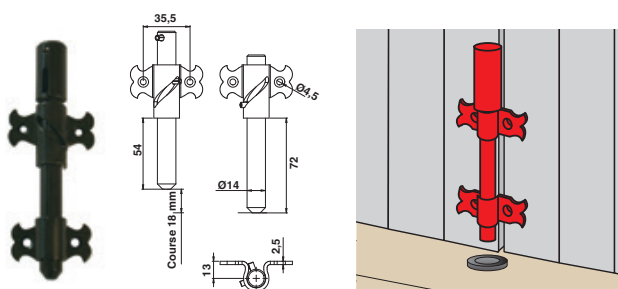

Verrou automatique

Code	Color	L	Dispo. (sem.)
Modèle bas			
P3140309B	Black	1600	5 1
Modèle haut			
P3140309H	Black	2500	5 4

Remplace la dardenne. Condamne automatiquement le volet par un mouvement hélicoïdal au verrouillage de la poignée d'espagnolette. Bien graisser le produit au montage.

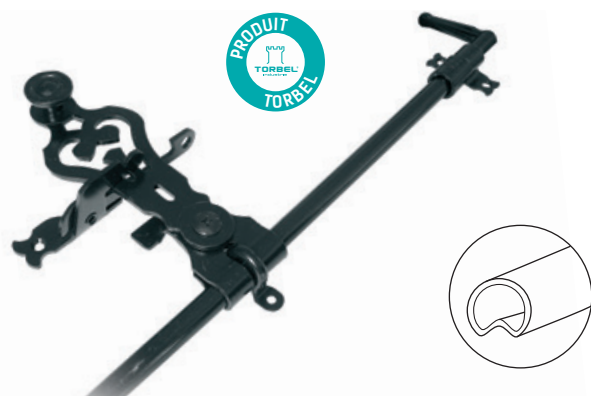

- Simplicité de stockage et de pose.
- Une seule coupe permet la mise à dimension de la tige.
- Tous les accessoires s'alignent grâce à la rainure.
- Le positionnement des lacets haut et bas sur les embouts garantit une tenue parfaite après assemblage même en cas de recoupe à hauteur de poignée.
- Ce produit breveté est totalement réversible et équipé d'un support de sécurité.
- L'utilisation des tubes de longueur 4600 mm permet de limiter les chutes.

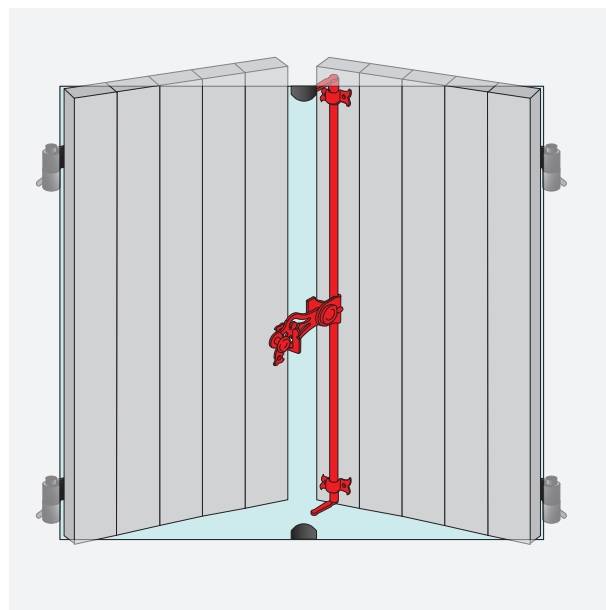

Tringle rainurée creuse

Code		L		Dispo. (sem.)
07TR134		1270	10	1
07TR164		1570	10	1
07TR214		2070	10	1
07TR244		2400	10	1
07TR464		4600	50	1



Composition

- 1 poignée, 1 panneton
- 1 boulon TUBRAIN®
- 1 embout haut
- 1 embout bas
- 2 lacets rustiques
- 1 lacet fil rond
- 1 support de sécurité



Composition

- 1 poignée, 1 panneton
- 1 boulon TUBRAIN®
- 1 embout courbe haut
- 1 embout courbe bas
- 2 lacets rustiques
- 1 lacet fil rond
- 1 support de sécurité

Sachet d'accessoires TUBRAIN® (crochets droits)

Code		L		Dispo. (sem.)
07TRS16		20		1

Sachet d'accessoires TUBRAIN® (crochets courbes)

Code		L		Dispo. (sem.)
07TRS36		25		1



- Simplicité de pose
- Réglage simple par recoupe du rond plein
- Position réglable de la poignée
- Poignée et lacets en fonte

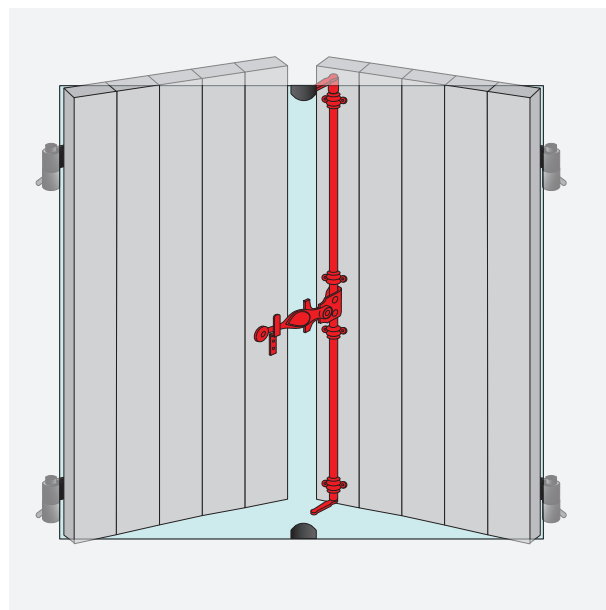

Tringle rond plein
Crochets droits soudés

Code		L		Dispo. (sem.)
0420164		1600	5	1
0420204		2000	5	1
0420254		2500	1	1



Composition

- 1 poignée montée sur panneton
- 1 vis écrou
- 2 lacets fonte
- 2 demi-lacets fonte
- 1 support

Sachet d'accessoires Ardenne

Code			Dispo. (sem.)
J620201		5	1



- Encombrement réduit de la poignée.
- Mise à longueur de la tringle en une seule coupe.
- Positionnement de la poignée par coulissement sur la tringle.
- Blocage de la poignée par une vis sur le fer.

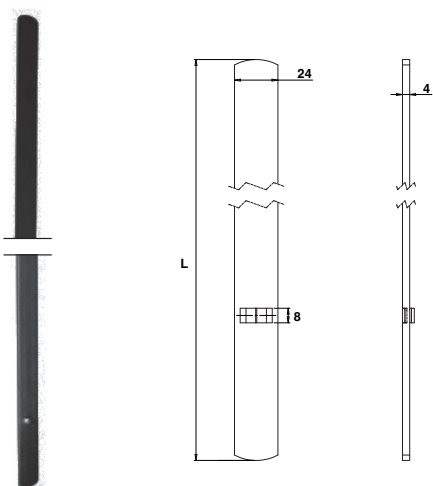
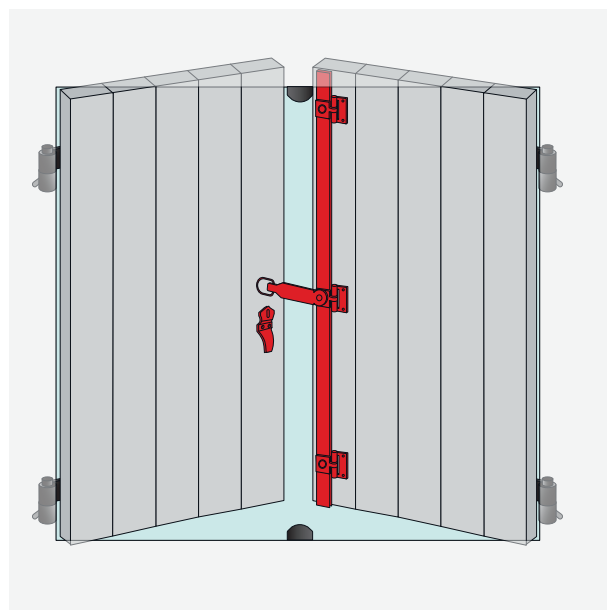

Tige plate NM 25

Code		L		Dispo. (sem.)
P32003150		1500	10	1
P32003200		2000	10	1
P32003250		2500	5	1



Composition

- 1 poignée
- 1 support
- 2 arrêts haut et bas
- 3 charnières pour 1,50 m ou 2, 4 m
- ou 4 charnières pour 2,50 m

Sachet espagnolettes plates NM 25 fléau courbe

Code			Dispo. (sem.)
3 charnières			
P3210303C		20	1
4 charnières			
P3210304C		20	1



Étudiée pour équiper les persiennes, l'espagnolette plate Éco séduira les poseurs à la recherche du meilleur rapport qualité/prix. Encombrement réduit.

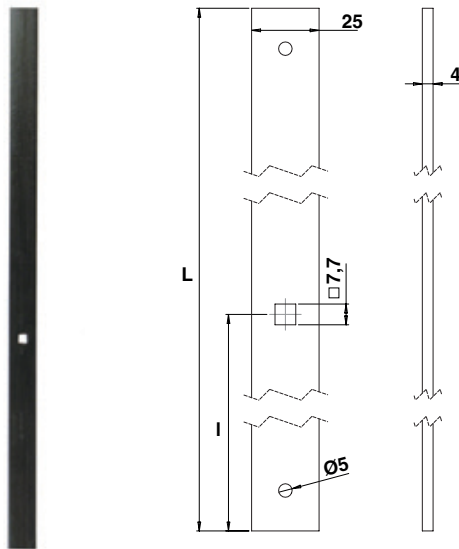
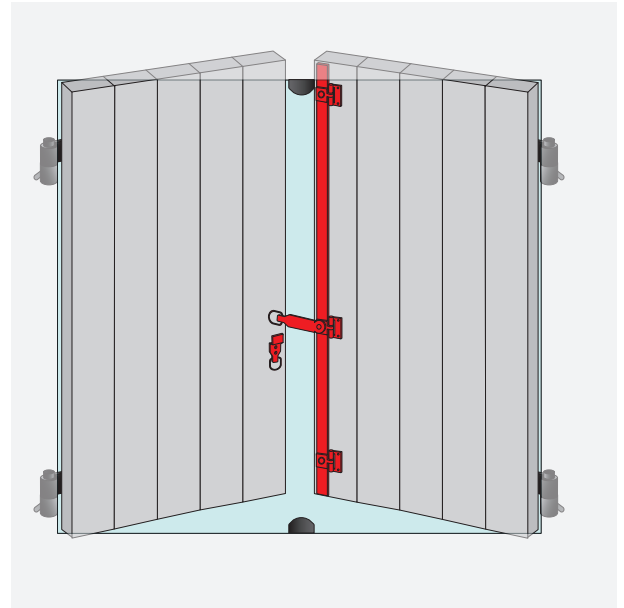

Tige plate Éco

Code		L	I		Dispo. (sem.)
0610154		1500	500		1
0610204		2000	700		1
0610254		2500	1100		1

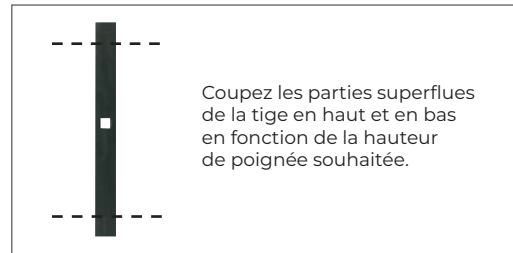

Composition

- 3 ou 4 lacets
- 1 support
- 3 lacets pour 1,5 ou 2 m
- 4 lacets pour 2,5 m

Sachet d'accessoires espagnolette plate Éco

Code			Dispo. (sem.)
3 lacets			
0612S14		10	1
4 lacets			
0612S24		10	NC

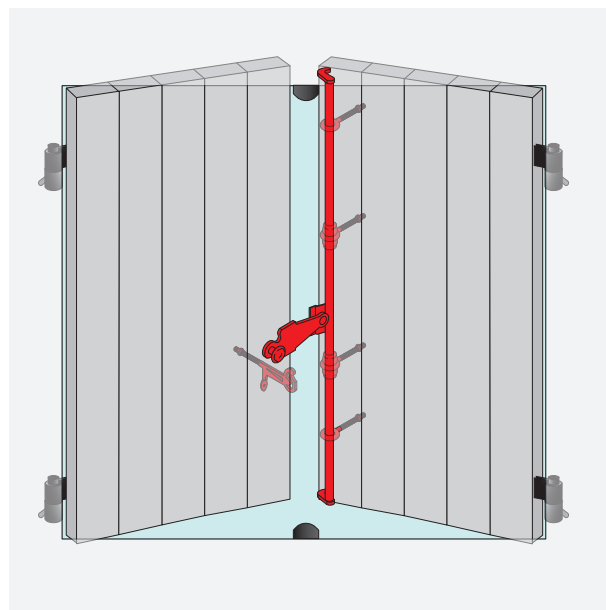

Nos lacets sont réversibles, pour un montage inversé, sortir l'axe et le remonter dans l'autre sens de sorte à ce que la tête de l'axe se trouve en haut.







Nous composons les modèles souhaités à la demande.



Vous devez alors préciser :

- Le type de crochets

073001 Crochet droit	073003 Crochet courbe
	
- Le type de lacets

074008 Lacet à pattes rond	074560 Lacet à écrou
	
- Le type de poignée

0701 Poignée feuille	0701 Poignée pleine
	
- Le type de support

075225 Support rustique	075025 Support plein à écrou
	
- La longueur et le revêtement

- La longueur de l'espagnolette peut être ajustée par nos soins.

Espagnolette HNS - Crochet du Haut Non Soudé

Code	L	Dispo. (sem.)
Poignée pleine - Lacet à pattes - Crochet droit		
0205164	1600	1
0205254	2500	1
Poignée feuille - Lacet à pattes - Crochet droit		
0205184	1600	1
0205274	2500	1
Poignée pleine - Lacet à écrou - Crochet courbe		
0202174	1600	2
0202264	2500	2
Poignée pleine - Lacet à pattes - Crochet courbe		
0205264	2500	2
Poignée feuille - Lacet à écrou - Crochet droit		
0202184	1600	2

1

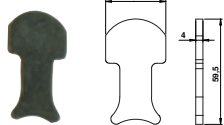

2

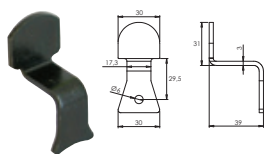

3

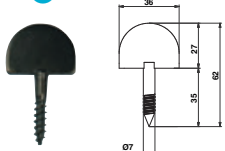

4

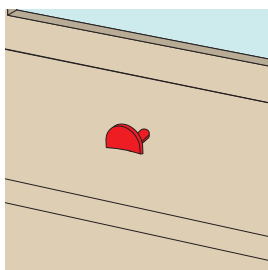
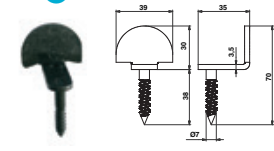

Dardenne

Code   Dispo. (sem.) U

Code	Quantité	Dispo. (sem.)	U
1 Droite à sceller 0710044	100	1	%
2 Coudée à sceller 9151011	20	1	P
3 Droite à vis Ø7 0710564	50	1	%
0710566	50	1	%
4 Coudée à vis 0710574	50	1	%



Trous fraisés épaisseur 4 mm

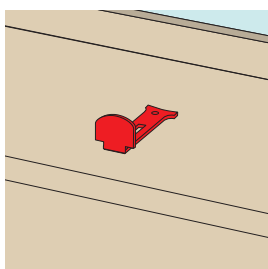
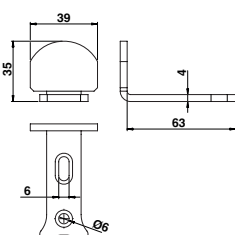

Dardenne type L

Code   Dispo. (sem.) U

07KR024	50	1	%
---------	----	---	---

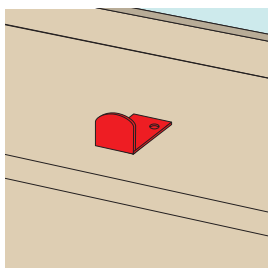
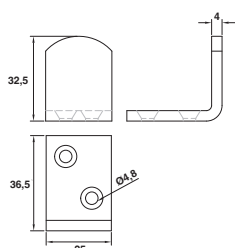

Dardenne coudée

Code   Dispo. (sem.)

J502007	50	1
---------	----	---

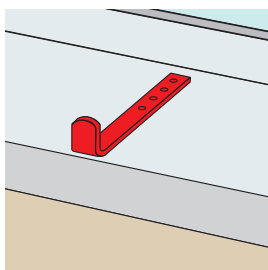
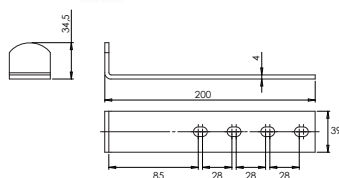

Dardenne type L

Code   Dispo. (sem.)

07KS604	40	4
---------	----	---

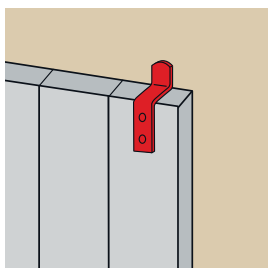
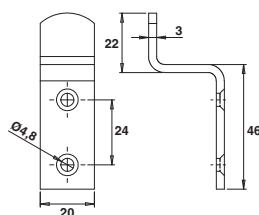

Dardenne contre-coudée

Code   Dispo. (sem.) U

J502048	50	1	%
---------	----	---	---

0765083
Arrêt du haut



0765103
Arrêt du bas

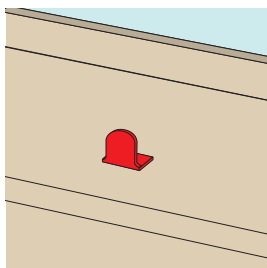
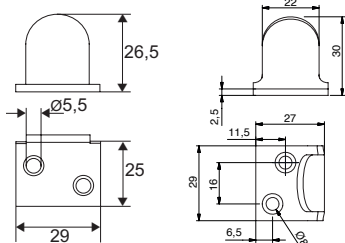

Arrêt

Code	Dispo. (sem.)	U
Haut		
0765083	50	1 %
Bas		
0765103	50	1 %

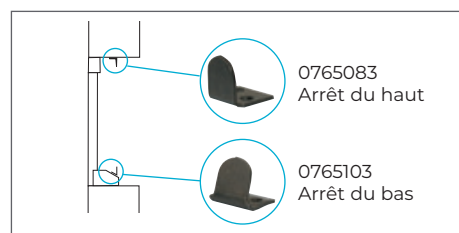

0720054 - Droit à vis

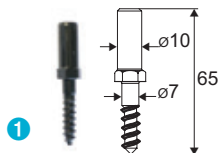

0720046 - Coudé à vis

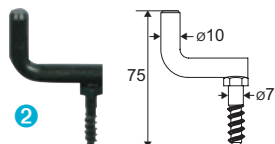

0720014 - Droit à sceller

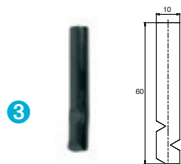

0720024 - Coudé à sceller

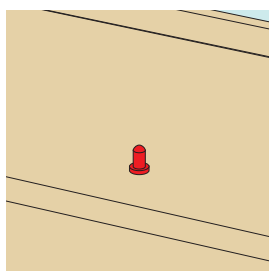
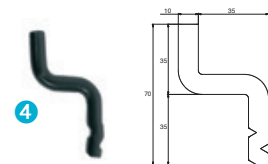

Goujon pour espagnolette à crochet courbe

Code	Dispo. (sem.)	U
1 Droit à vis		
0720054	50	1
2 Coudé à vis		
0720046	50	1
3 Droit à sceller		
0720014	50	4
4 Coudé à sceller		
0720024	50	4

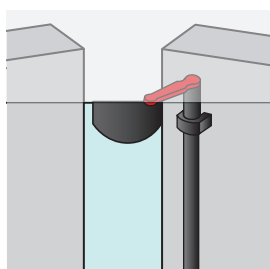
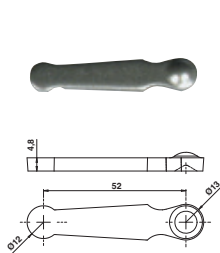

Crochet droit à bossage à souder sur rond Ø14

Code	Dispo. (sem.)	U
0730010	BRUT 100	4 %

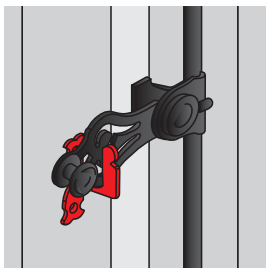
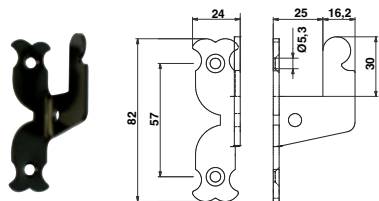

Support rustique

Code	Dispo. (sem.)
0752254	100 1

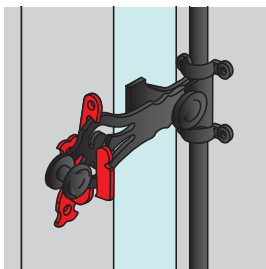
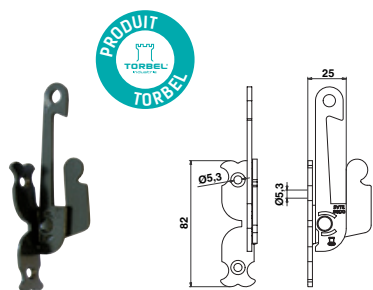

Support sécurité sur platine

Code	Dispo. (sem.)
0753014i	1 1

En position fermée, le support de sécurité TORBEL® empêche toutes manipulations intempêtes de la poignée depuis l'extérieur.

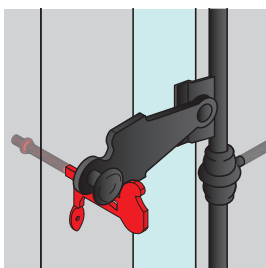
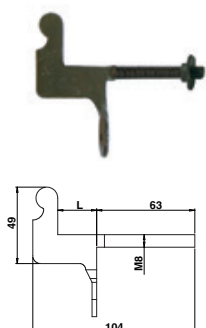

Support plein à écrou

Code	Dispo. (sem.)
0750253	100 1

Utilisez la clé carbonitrée réf: 0765920, pour les supports et les lacets à écrous.



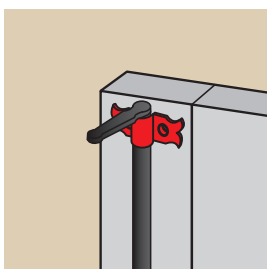
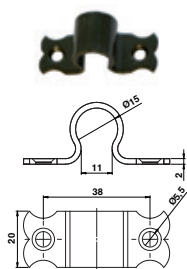

Lacet rustique à pattes

Code



Dispo.
(sem.)

0740054

200

1

Les 4 modèles de lacets permettent de compléter les ensembles d'accessoires standards.

Pour la fixation de nos lacets, utiliser des vis Ø5.

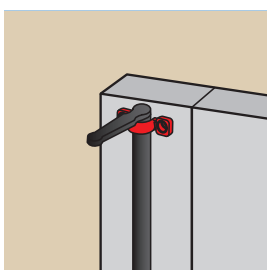
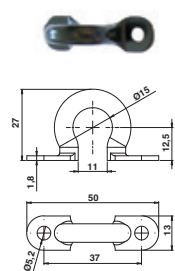

Lacet rond à patte

Code



Dispo.
(sem.)

0740084

100

1

Les 4 modèles de lacets permettent de compléter les ensembles d'accessoires standards.

Pour la fixation de nos lacets, utiliser des vis Ø5.

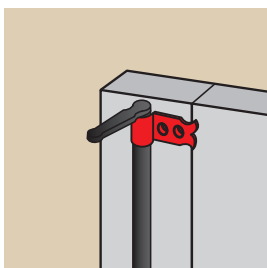
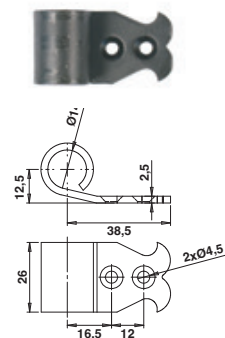

Lacet déporté à patte

Code



Dispo.
(sem.)

P31403802

200

1

Lacet déporté long à patte

Code



Dispo.
(sem.)

0740024

100

2

Les 4 modèles de lacets permettent de compléter les ensembles d'accessoires standards. Le lacet déporté long renforce le maintien des espagnolettes en se fixant sur 2 lames.

Pour la fixation de nos lacets, utiliser des vis Ø5.

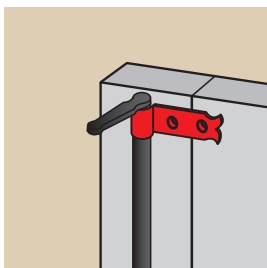
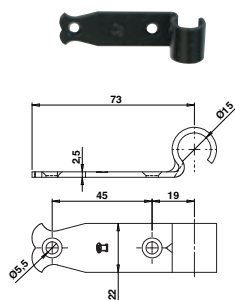

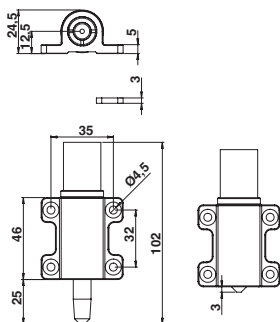

Verrou SDO pêne long 46 mm alu + accessoires laquables

Code	Color	Dispo. (sem.)
Modèle haut		
95PA039	Black	10
95PA049	White	10
Modèle bas		
95PA019	Black	10
95PA029	White	10

Verrou SDO pêne long 66 mm inox + accessoires laquables

Code	Color	Dispo. (sem.)
Modèle haut		
95PA659	Black	10
Modèle bas		
95PA649	Black	10

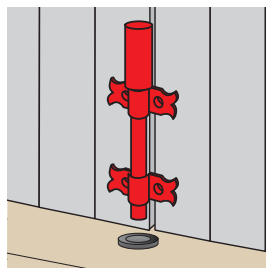
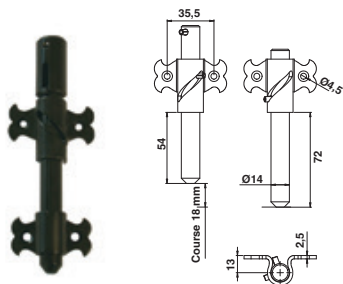

Verrou automatique

Code	Color	Dispo. (sem.)
Modèle bas		
P3140309B	Black	5
Modèle haut		
P3140309H	Black	5

Remplace la dardenne. Condamne automatiquement le volet par un mouvement hélicoïdal au verrouillage de la poignée d'espagnolette. Bien graisser le produit au montage.

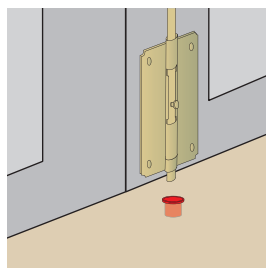
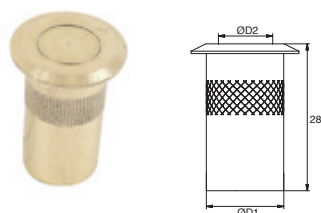

Gâche à ressort antipoussière

Code	Color	ØD1	ØD2	Dispo. (sem.)
95PAA39	LAITON	16	12	100
95PAA49	LAITON	18	14	100

Lacets

Soumis à la REP PMCB.

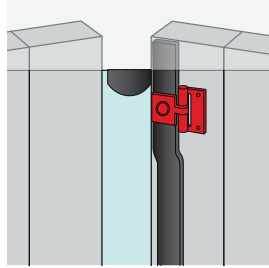
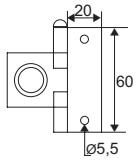

Lacet coulissant

Code	Color	Dispo. (sem.)
0740294	Black	1

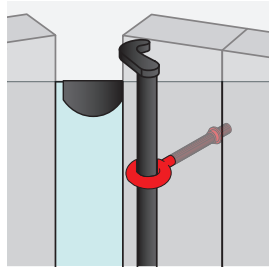
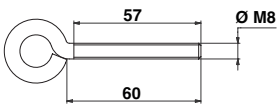

Lacet + écrou

Code	Color	Dispo. (sem.)
0745603	Black	10

Crochet de rappel

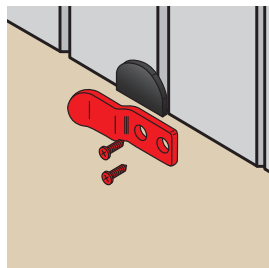
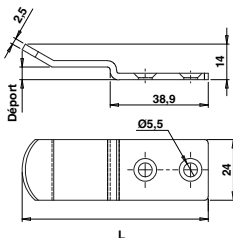

Crochet de rappel

Code	Color	L	Déport	Ep.	Dispo. (sem.)	U
9210014	Black	74	5	2,5	50	1 P
0311704	Black	75	9	3	1	2 %

Economise la pose d'une espagnolette.

