

Demi-sabot composite débouchant

Code



Dispo.
(sem.)

Avec plots de centrage

77003780  500 1

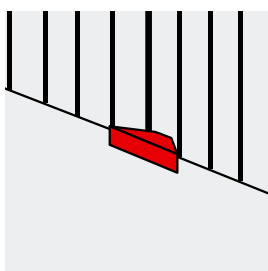

Demi-sabot composite non débouchant

Code



Dispo.
(sem.)

Avec plots de centrage

7700306  500 4

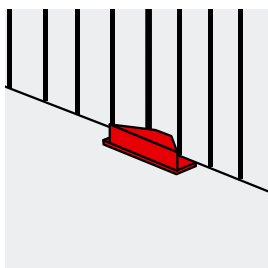

Demi-sabot composite monté sur petite platine

Code



Dispo.
(sem.)

P77007790 **GALVA.**  200 1

Sabots

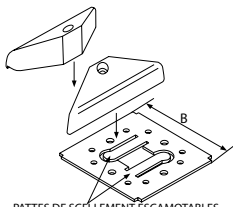

Soumis à la REP PMCB.

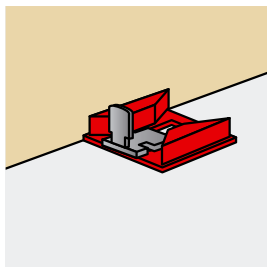

PATTES DE SCELLEMENT ESCAMOTABLES





Sabot de guidage composite monté sur platine

Code		B		Dispo. (sem.)
P77307128	GALVA.	28	100	1
P77307131	GALVA.	31	100	1

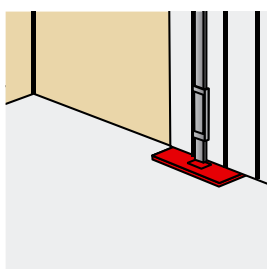
Platine en acier avec pattes à sceller intégrées pour une pose à sceller ou à visser.



Demi-sabot verrou composite monté sur platine

Code		B	e		Dispo. (sem.)
P77407128	GALVA.	28	2	100	1
P77407131	GALVA.	31	2	100	1

Platine en acier avec pattes à sceller intégrées pour une pose à sceller ou à visser.

Verrous

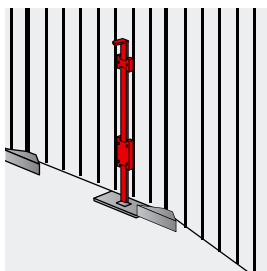
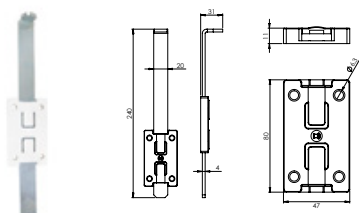

Verrou composite court

Code			Dispo. (sem.)
92PC001	Z.BLANC	50	1

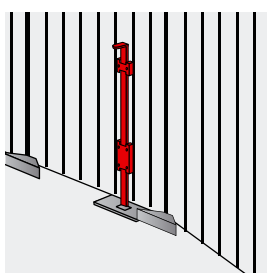
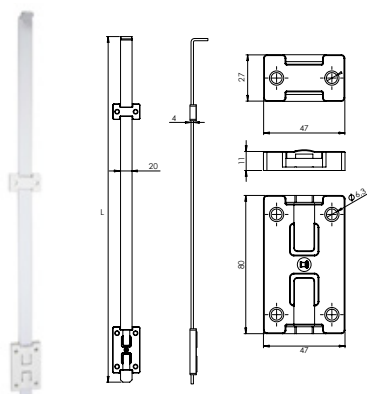

Verrou composite long

Code			Dispo. (sem.)
92PC105	Z.BLANC	25	1