

Charnières de milieu

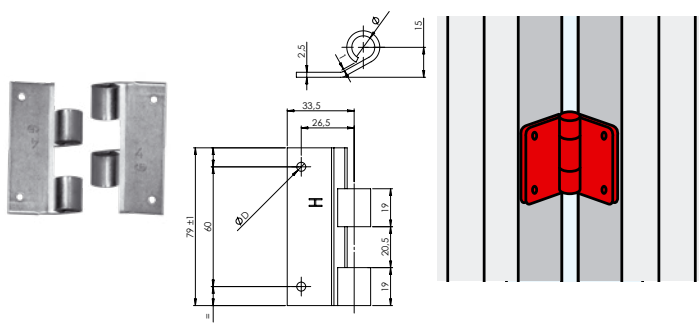

P750012.. Charnière sur chant bouts carrés 2 trous (Fourni sans axe)

Code		Ø	Ep.	ØD		Dispo. (sem.)
P750012HO	Z.BLANC	11	2,5	4,5	100	STOCKÉ

Compatible avec axe P.426

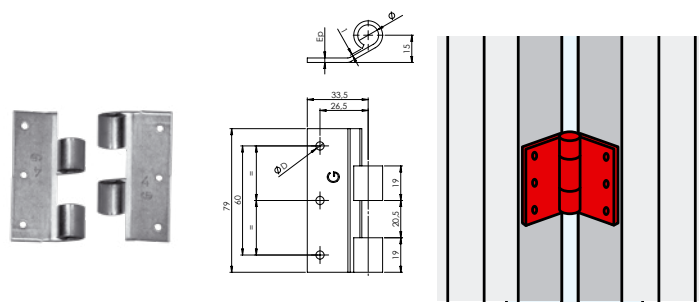

P750022.. Charnière sur chant bouts carrés 3 trous (Fourni sans axe)

Code		Ø	Ep.	ØD		Dispo. (sem.)
P750022GO	Z.BLANC	11	2,5	4,5	100	STOCKÉ

Compatible avec axe P.426

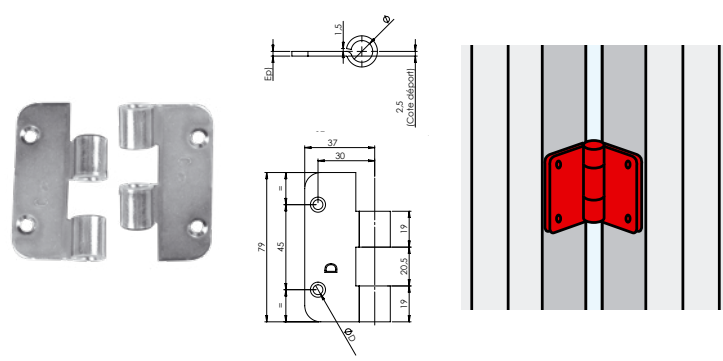

P750020.. Charnière sur chant bouts ronds 2 trous (Fourni sans axe)

Code		Ø	Ep.	ØD		Dispo. (sem.)
P750020DO	Z.BLANC	11	2,5	5,2	50	STOCKÉ

Code		Ø	Ep.	ØD		Dispo. (sem.)
P750020CO	Z.BLANC	11	2,5	6,2	100	4

Compatible avec axe P.426

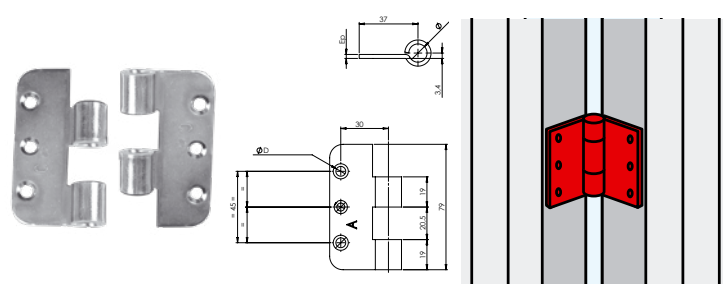

P750020.. Charnière sur chant bouts ronds 3 trous (Fourni sans axe)

Code		Ø	Ep.	ØD		Dispo. (sem.)
P750020AO	Z.BLANC	11	2,5	6,2	50	STOCKÉ

Code		Ø	Ep.	ØD		Dispo. (sem.)
P750020BO	Z.BLANC	11	2,5	5,2	50	4

Compatible avec axe P.426

Charnières d'extrémité

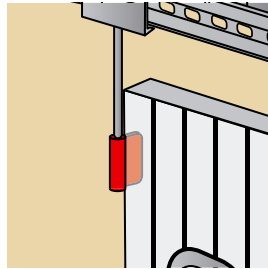
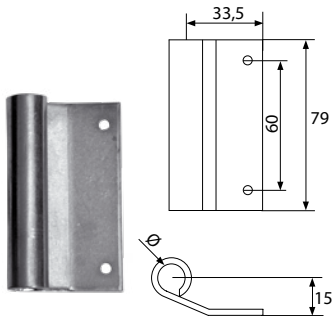

P750028.. Charnière d'extrémité sur chant bouts carrés 2 trous

Code		Ø	Ep.	ØD		Dispo. (sem.)
P750028H0	Z.BLANC	11	2,5	4,4	100	4

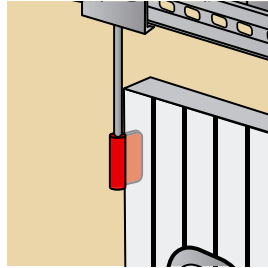
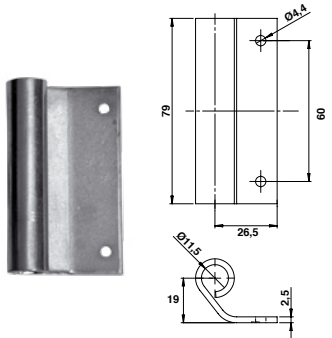

P750026.. Charnière d'extrémité sur chant bouts carrés 2 trous angle 52°

Code		Ø	Ep.	ØD		Dispo. (sem.)
P750026L0	Z.BLANC	11	2,5	4,4	100	4

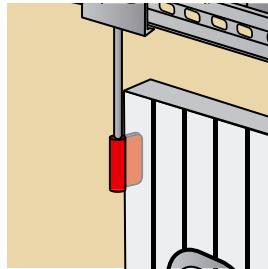
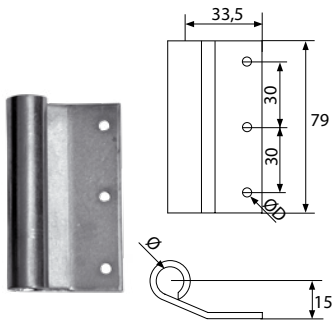

P750028G0 Charnière d'extrémité sur chant bouts carrés 3 trous

Code		Ø	Ep.	ØD		Dispo. (sem.)
P750028G0	Z.BLANC	11	2,5	4,4	100	4

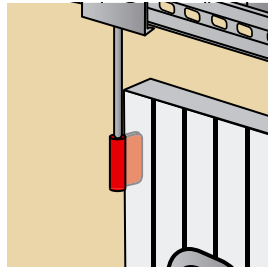
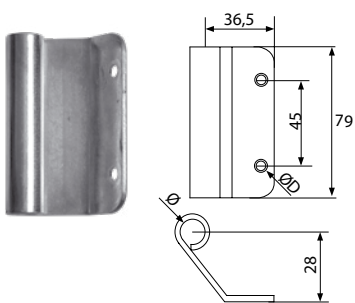

P750026C0 Charnière d'extrémité sur chant bouts ronds 2 trous

Code		Ø	Ep.	ØD		Dispo. (sem.)
P750026C0	Z.BLANC	11	2,5	6,2	100	STOCKÉ

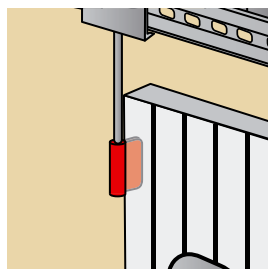
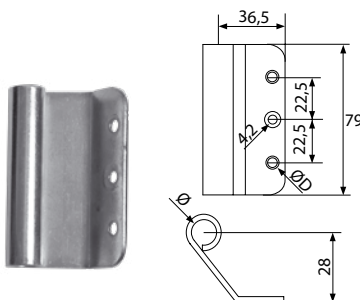

P750026.. Charnière d'extrémité sur chant bouts ronds 3 trous

Code		Ø	Ep.	ØD		Dispo. (sem.)
P750026A0	Z.BLANC	11	2,5	6,2	100	STOCKÉ

Code		Ø	Ep.	ØD		Dispo. (sem.)
P750026B0	Z.BLANC	11	2,5	5,2	100	4